

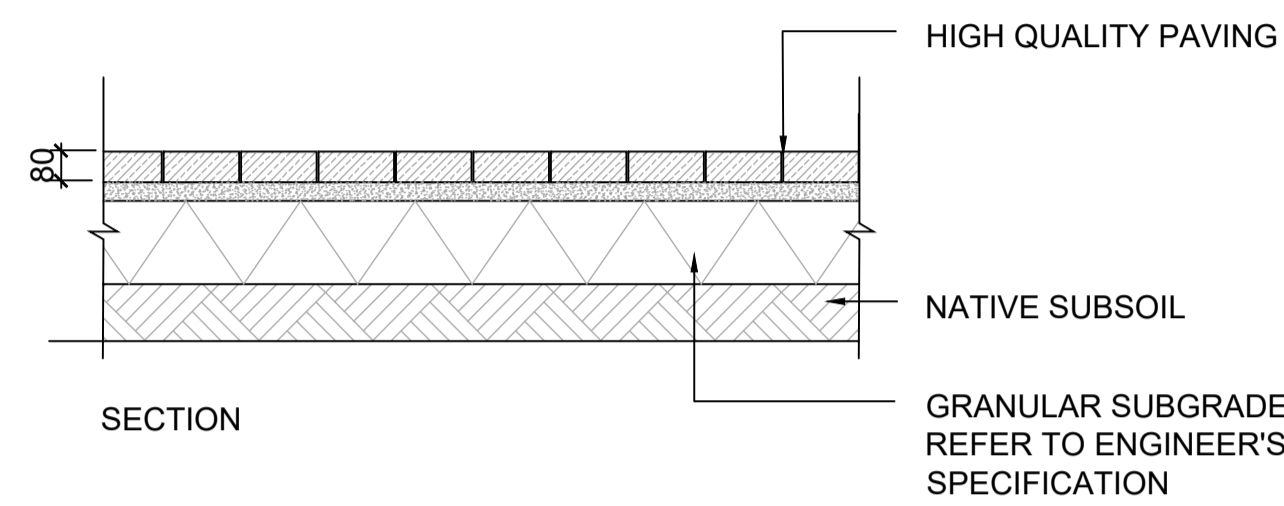

REFERENCE IMAGE

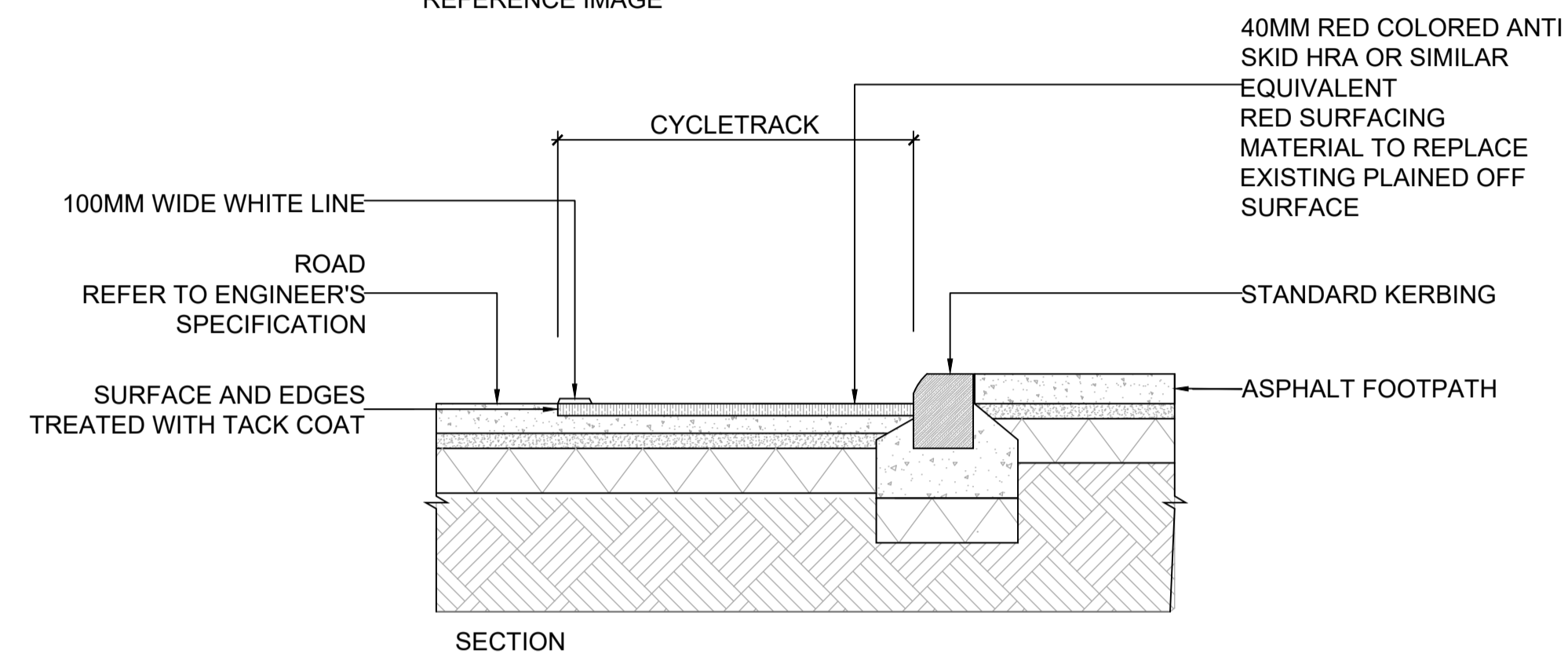

01 HIGH QUALITY PAVING
SCALE: 1:20 @A1



04 CYCLE PATH USING HARD SURFACING
SCALE: 1:20 @A1

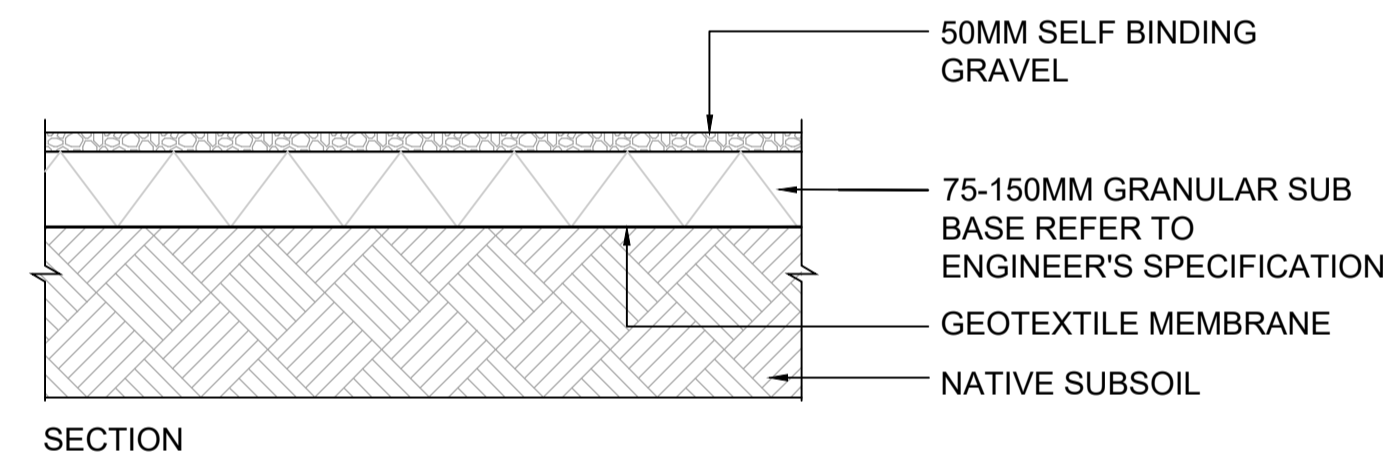

02 TYPICAL SELF BINDING GRAVEL SURFACE
SCALE: 1:20 @A1

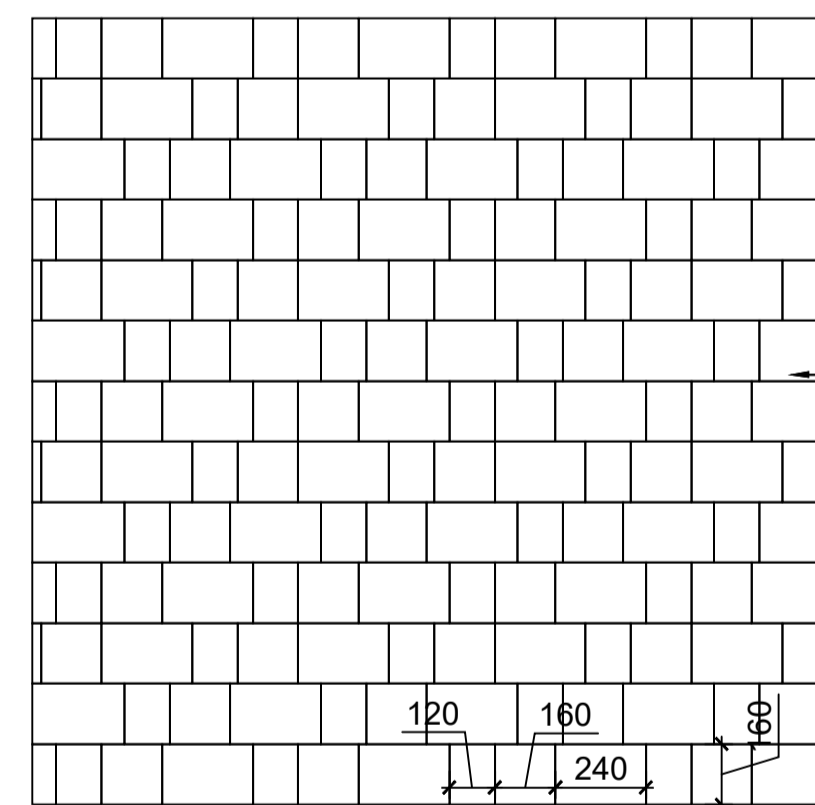

PLAN

KILSARAN CLIMA PAVE MELLIFONT BLOCK PAVING OR SIMILAR AND APPROVED CONCRETE PAVING, PRE-SEALED 3NO TONES:
NATURAL
240MM (L) X 160MM (W) X 80MM (D)
160MM (L) X 160MM (W) X 80MM (D)
120MM (L) X 160MM (W) X 80MM (D)

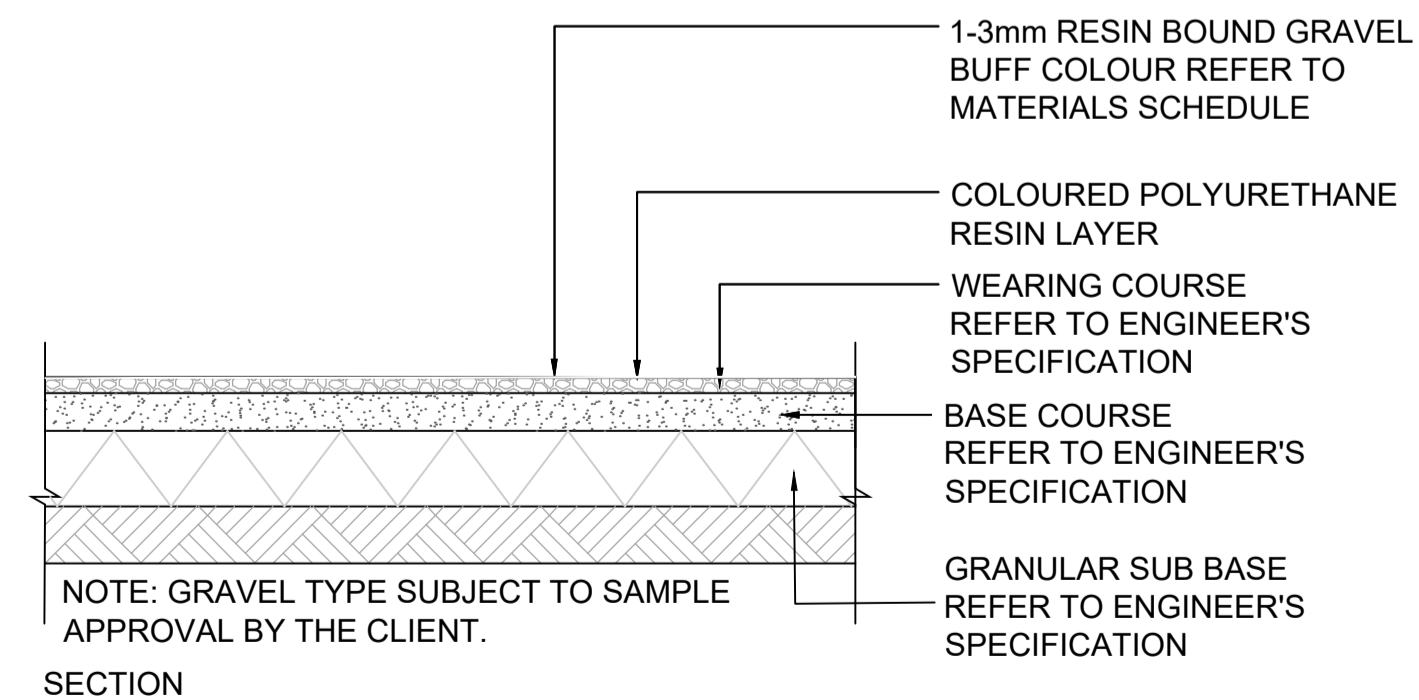

03 P6: TYPICAL RESIN BOUND GRAVEL
SCALE: 1:20 @A1

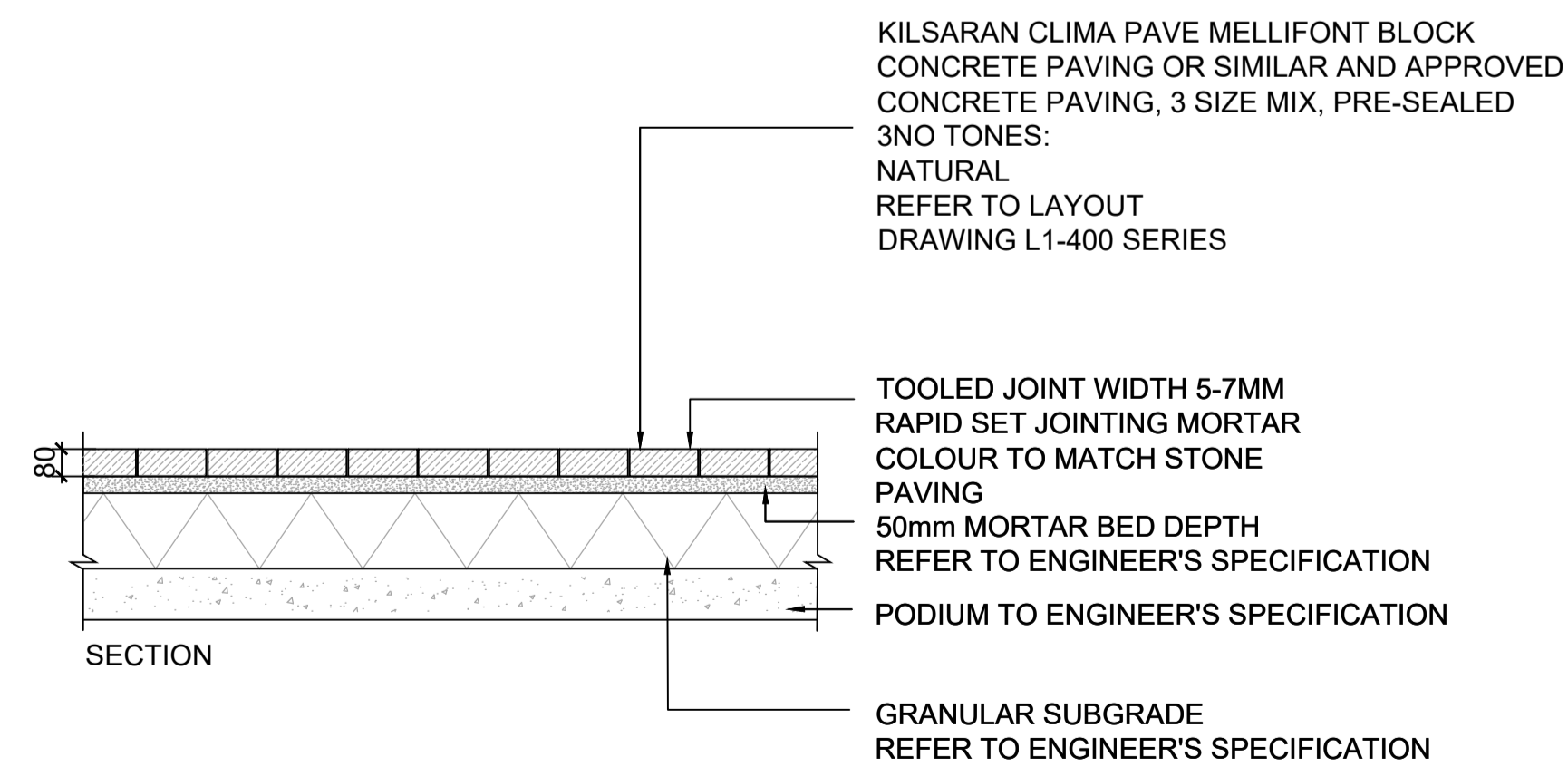

05 PARKING PERMEABLE PAVING
SCALE: 1:20 @A1

REFERENCE: THIS DRAWING IS NOT FOR CONSTRUCTION

**SR
LA**

SIMON RONAN LANDSCAPE ARCHITECTS

Cork Office: Levis Quay, Salsburgh, Co. Cork, Ireland, A94A431
Dublin Office: 25 Glengarriff Parade, Phibsborough, Dublin 7, Ireland, D07 XF25
simon@simonronan.com +353 86 056 3434

PAVING DETAILS L - 900 SCALE 1:20 A1

PURPOSE OF DRAWING - PLANNING

ROSS ROAD KILLARNEY

THIS DRAWING IS TO BE READ IN CONJUNCTION WITH ALL RELEVANT CONSULTANT'S DRAWINGS AND SPECIFICATIONS TO BE SCALED FROM THIS DRAWING. NO PART OF THIS DOCUMENT MAY BE REPRODUCED OR TRANSMITTED IN ANY FORM OR BY ANY MEANS, ELECTRONIC OR MECHANICAL, WITHOUT THE WRITTEN PERMISSION OF THE UNDERSIGNED. THE CLIENT ACCEPTS FULL RESPONSIBILITY FOR THE ACCURACY OF THE INFORMATION PROVIDED TO THE UNDERSIGNED AND THE UNDERSIGNED ACCEPTS FULL RESPONSIBILITY FOR THE ACCURACY OF THE INFORMATION PROVIDED TO THE CLIENT.

JULY 2025

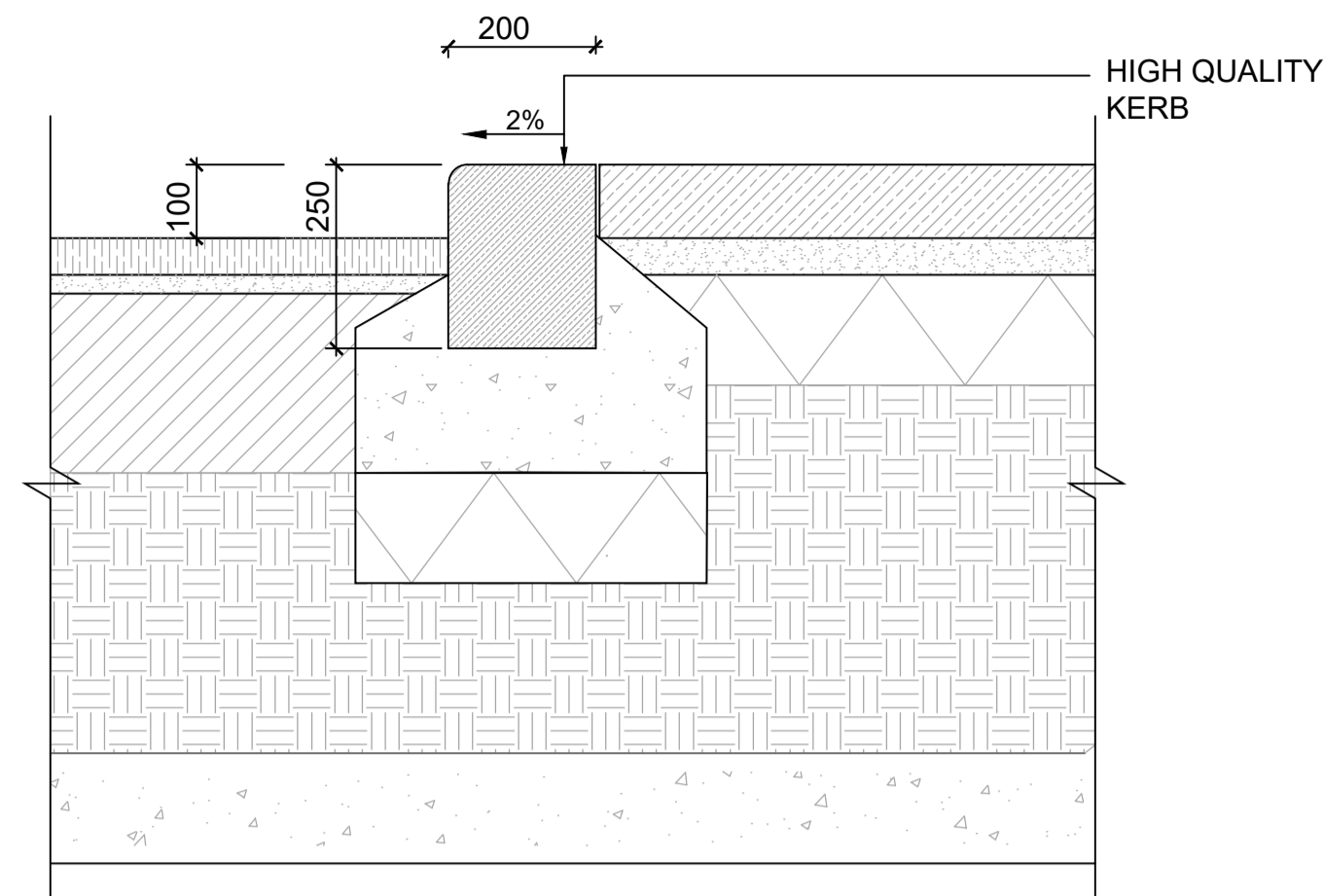

01 RAISED KERB
SCALE: 1:10 @A1

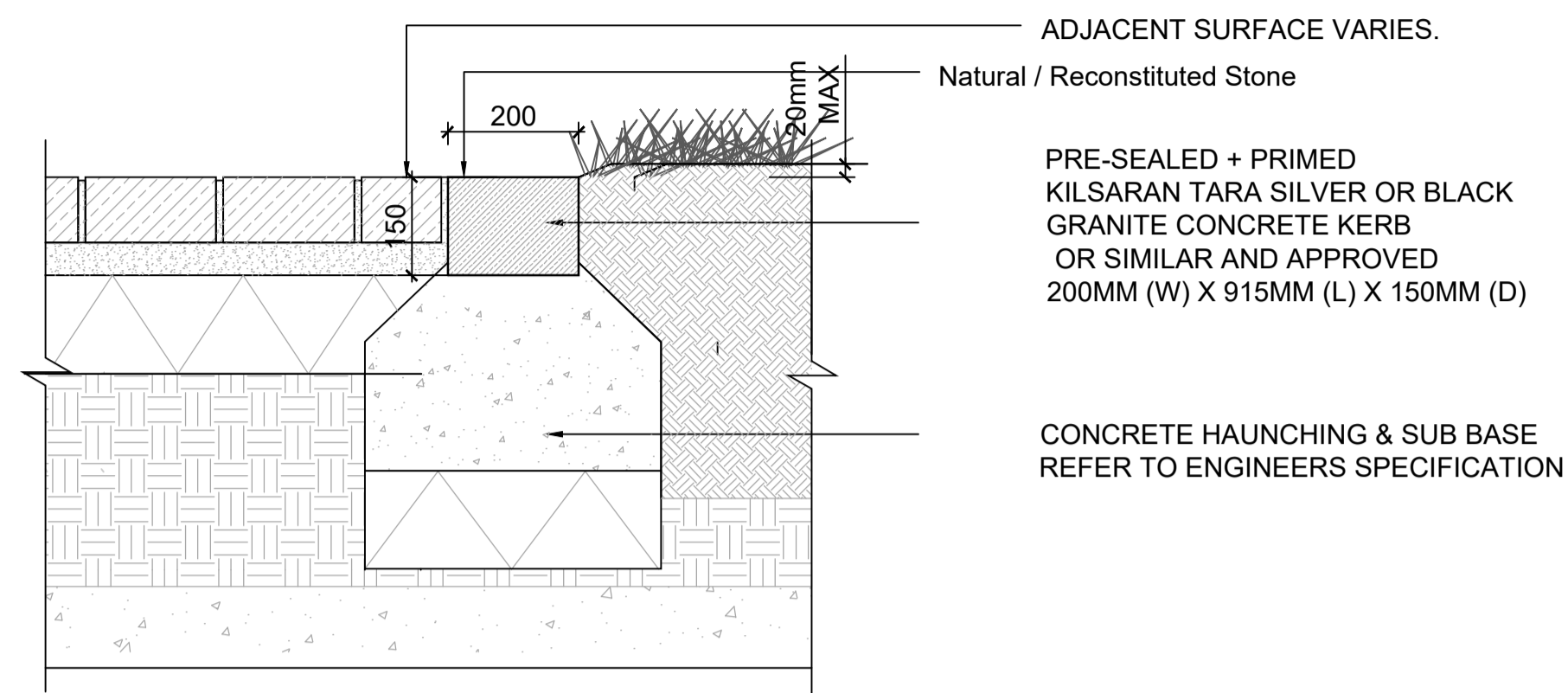

04 EDGING ADJACENT TO PLANTING AREA
SCALE: 1:10 @A1

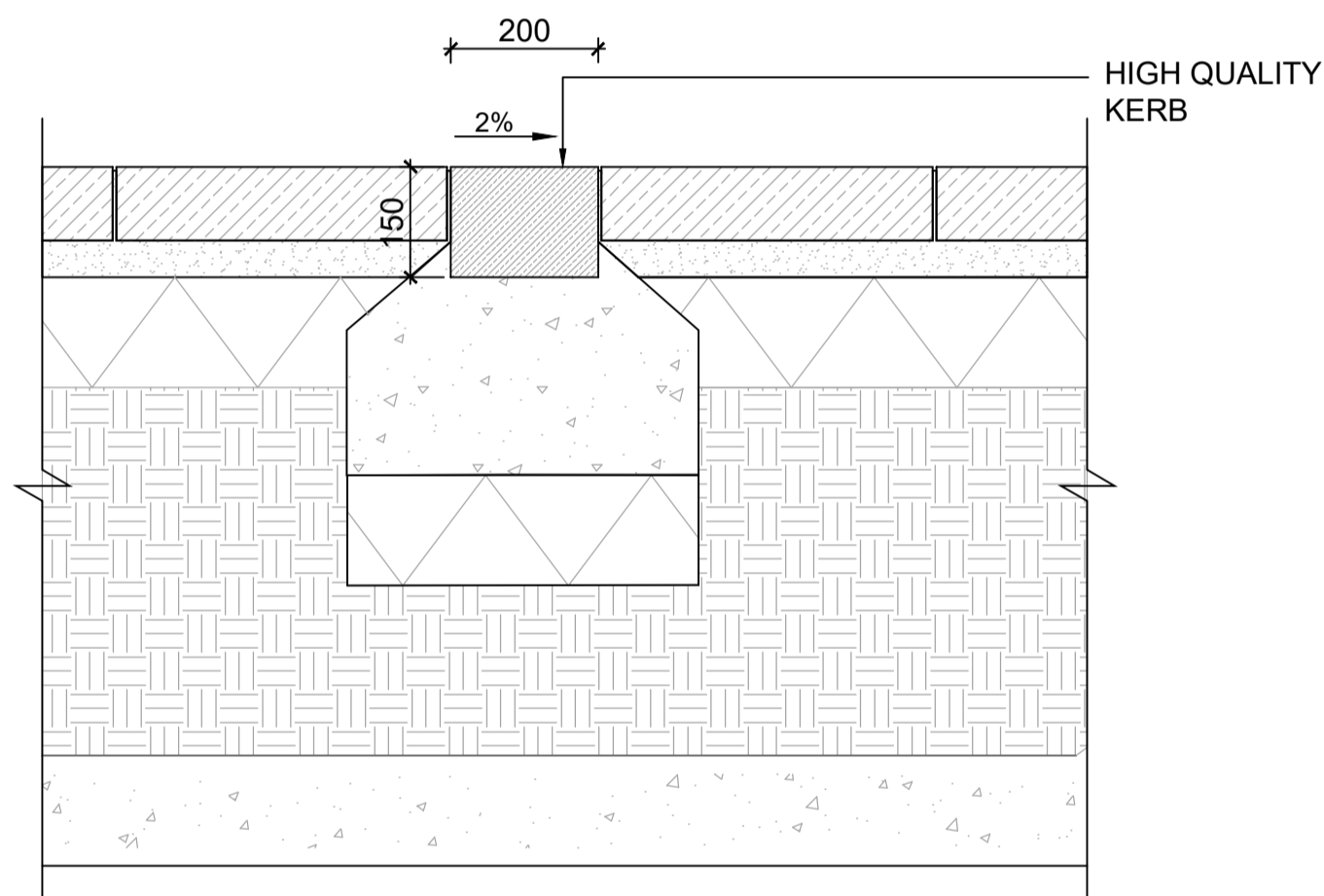

02 FLUSH KERB
SCALE: 1:10 @A1

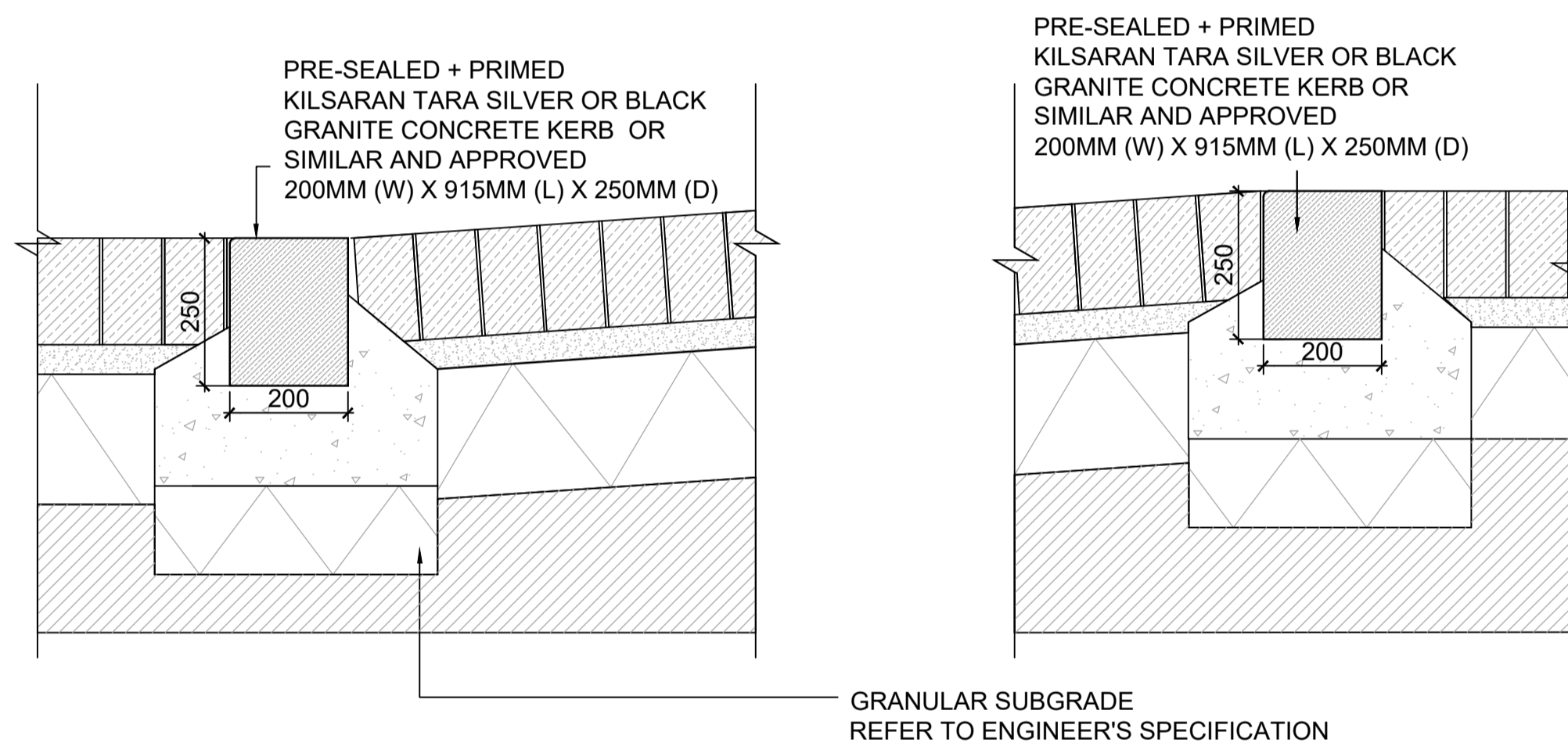

05 RAMP KERB AND PAVING INTERFACE
SCALE: 1:10 @A1

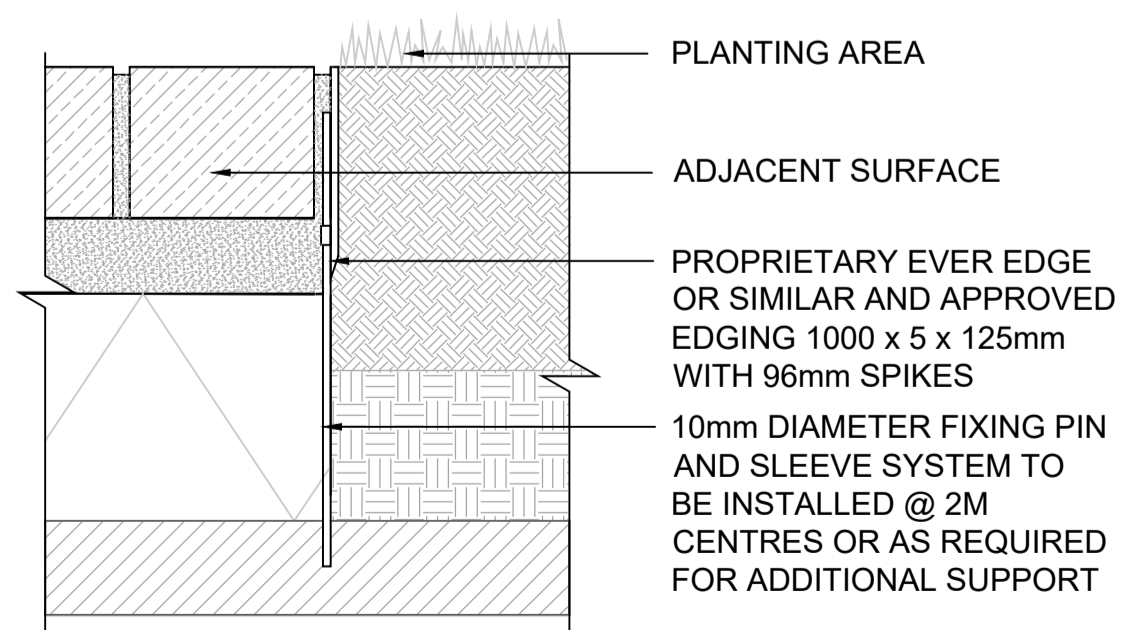

03 TYPICAL STEEL EDGING
SCALE: 1:5 @A1

REFERENCE: THIS DRAWING IS NOT FOR CONSTRUCTION

**SR
LA**

SIMON RONAN LANDSCAPE ARCHITECTS

Cork Office
Levis Quay
Sillibereen
Co. Cork
Ireland
A94A431
simon@simonronan.com

Dublin Office
25 Glengarriff Parade
Phibsborough
Dublin 7
Ireland
D07 XF25
+353 86 056 3434

EDGE DETAILS
L - 901

SCALE AS SHOWN
A1

PURPOSE OF DRAWING - PLANNING

ROSS ROAD KILLARNEY

THIS DRAWING IS TO BE READ IN CONJUNCTION WITH ALL PREVIOUS CONSULTANT'S DRAWINGS.
NO DIMENSIONS TO BE SCALED FROM THIS DRAWING.
NO PART OF THIS DOCUMENT MAY BE REPRODUCED OR TRANSMITTED IN ANY FORM OR BY ANY MEANS, ELECTRONIC OR MECHANICAL, INCLUDING PHOTOCOPYING, RECORDING, OR BY ANY INFORMATION STORAGE AND RETRIEVAL SYSTEM, WITHOUT THE WRITTEN PERMISSION OF THE ARCHITECTS. THIS DOCUMENT IS THE PROPERTY OF SIMON RONAN LANDSCAPE ARCHITECTS AND IS TO BE USED ONLY FOR THE PROJECT AND SITE SPECIFICALLY IDENTIFIED HEREIN.
DRAWN BY: SR/AR/ML/2025/1000001

JULY 2025

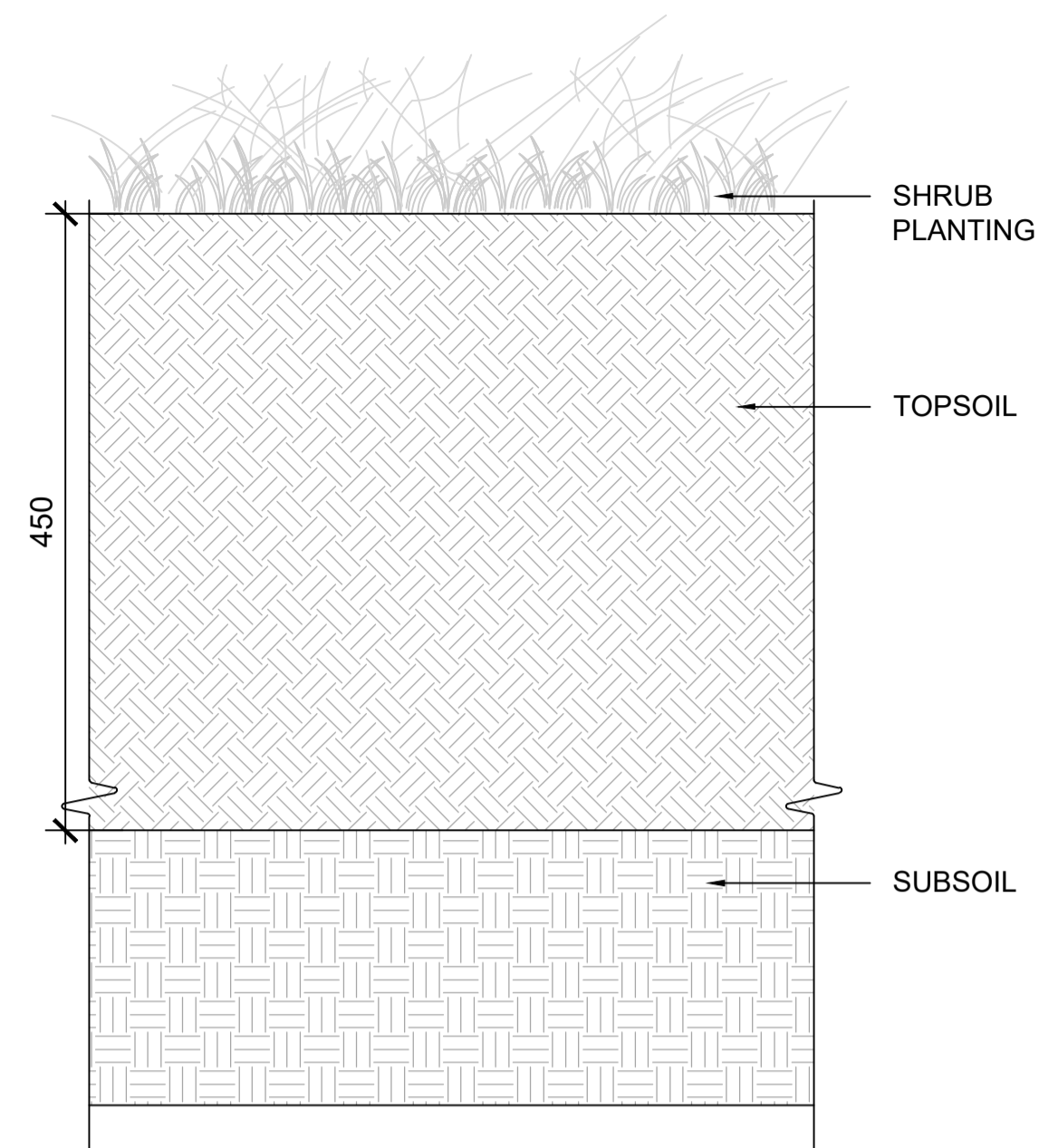

01 TYPICAL SHRUB SOIL PROFILE
SCALE: 1:5@A1

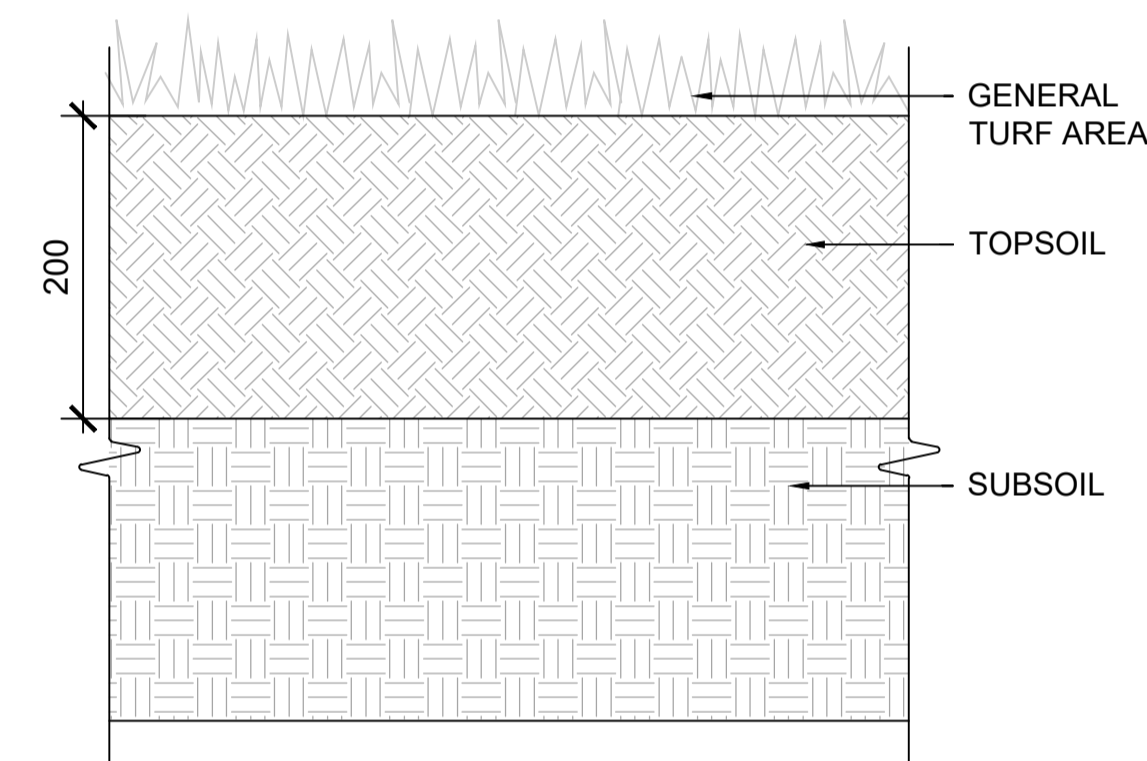

02 TYPICAL TURF SOIL PROFILE
SCALE: 1:5@A1

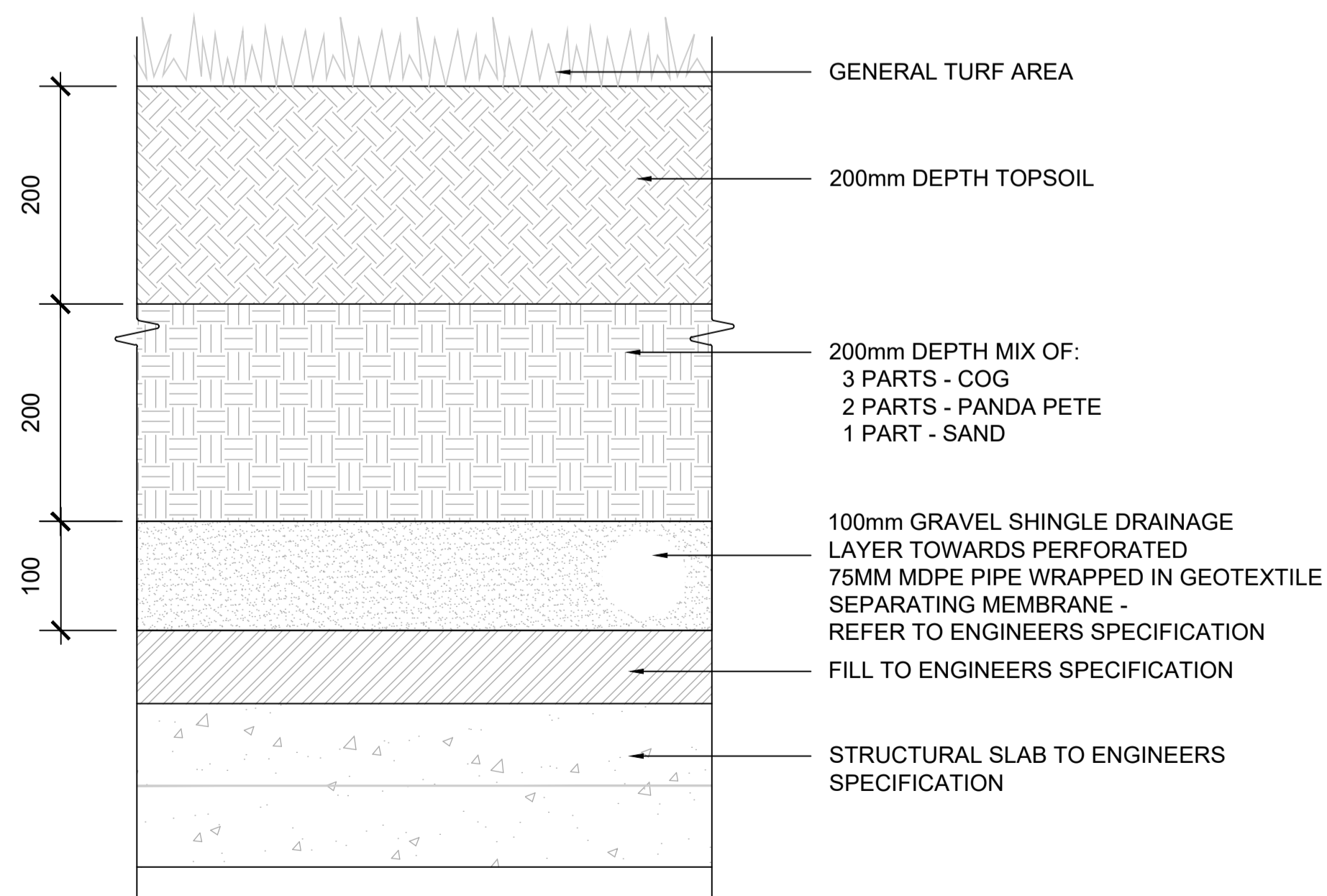

03 TYPICAL TURF SOIL PROFILE ON SLAB
SCALE: 1:5@A1

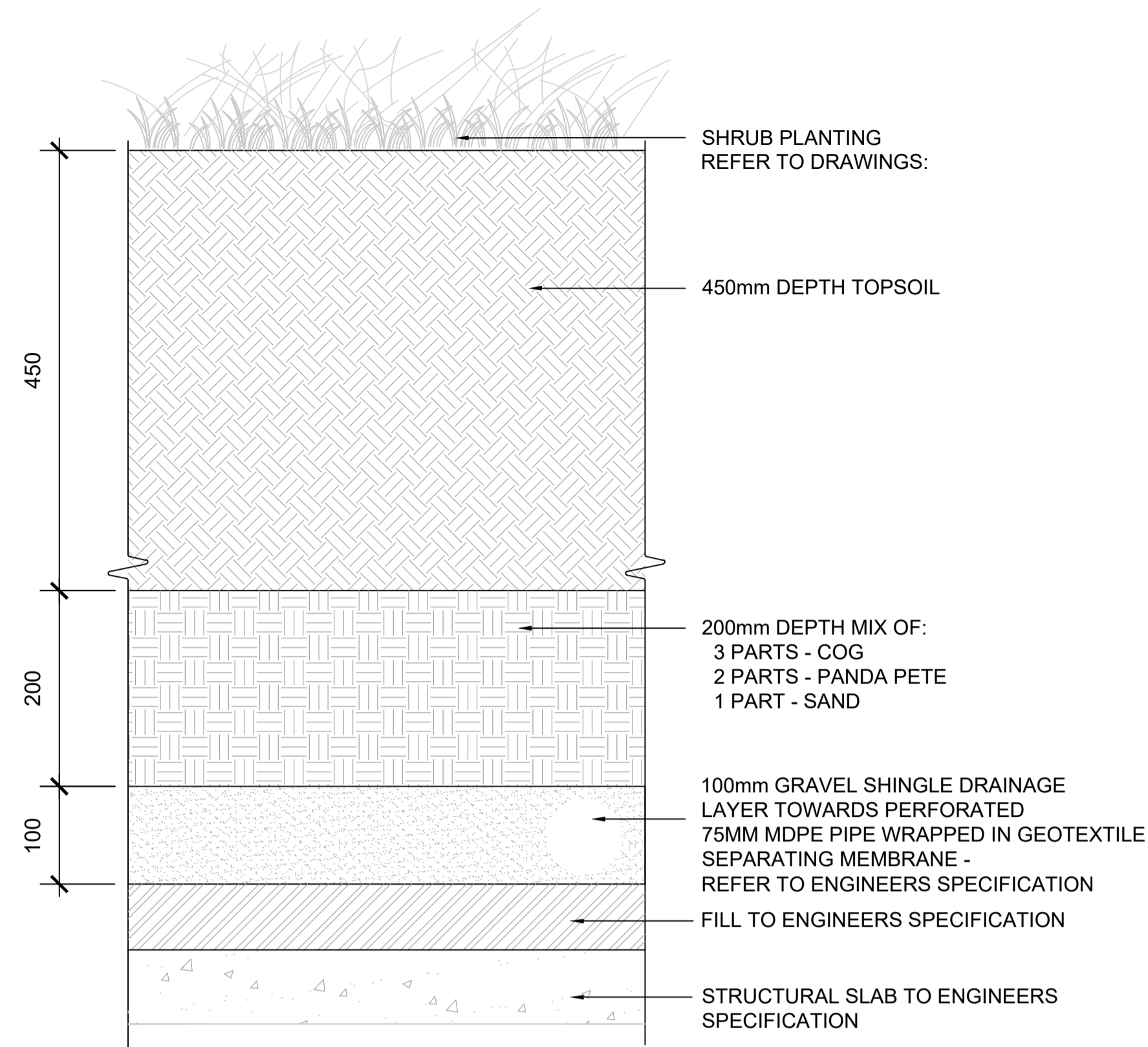

04 TYPICAL SHRUB SOIL PROFILE ON SLAB
SCALE: 1:5@A1

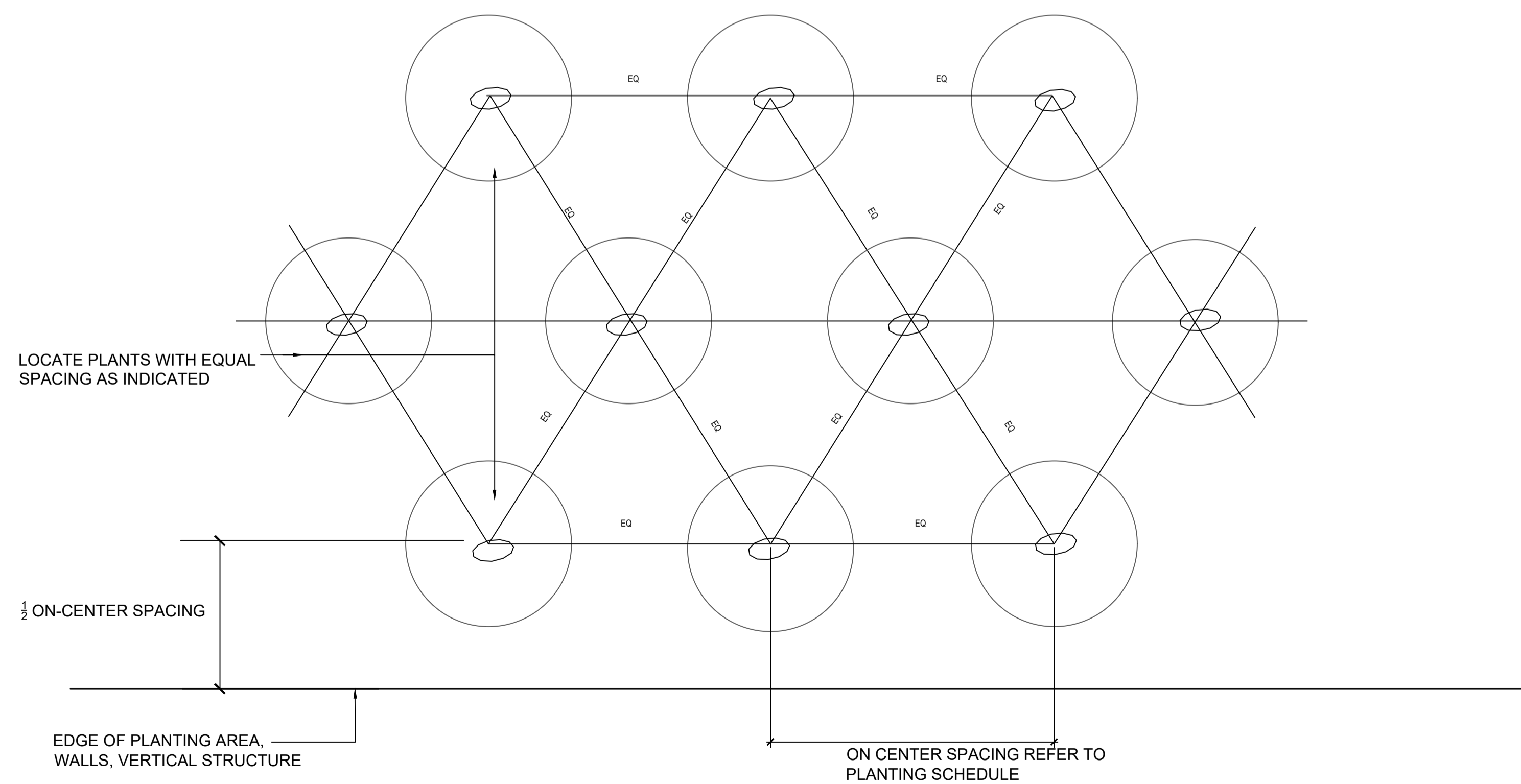

05 TYPICAL SHRUB PLANTING SPACING
SCALE: 1:20@A1

REFERENCE: THIS DRAWING IS NOT FOR CONSTRUCTION

SR LA
SIMON RONAN LANDSCAPE ARCHITECTS

Cork Office: Lewis Quay, Sillibereen, Co. Cork, Ireland, A94A431
Dublin Office: 25 Glengarriff Parade, Phibsborough, Dublin 7, Ireland, D07 XF25
simon@simonronan.com +353 86 056 3434

SOFT LANDSCAPE DETAILS | SCALE AS SHOWN
L - 902 | A1

PURPOSE OF DRAWING - PLANNING

ROSS ROAD KILLARNEY

THIS DRAWING IS TO BE READ IN CONJUNCTION WITH ALL NECESSARY CONSULTANT'S DRAWINGS AND SPECIFICATIONS TO BE OBTAINED FROM THE ARCHITECT.
NO DIMENSIONS TO BE SCALED FROM THIS DRAWING.
NO PART OF THIS DOCUMENT MAY BE REPRODUCED OR TRANSMITTED IN ANY FORM OR BY ANY MEANS, ELECTRONIC OR MECHANICAL, INCLUDING PHOTOCOPYING, RECORDING, OR BY ANY INFORMATION STORAGE AND RETRIEVAL SYSTEM, WITHOUT THE WRITTEN PERMISSION OF THE ARCHITECT. THIS DOCUMENT IS THE PROPERTY OF SIMON RONAN LANDSCAPE ARCHITECTS AND IS TO BE USED ONLY FOR THE PROJECT AND SITE SPECIFICALLY IDENTIFIED HEREIN.
DRAWN BY: SIMON RONAN

JULY 2025

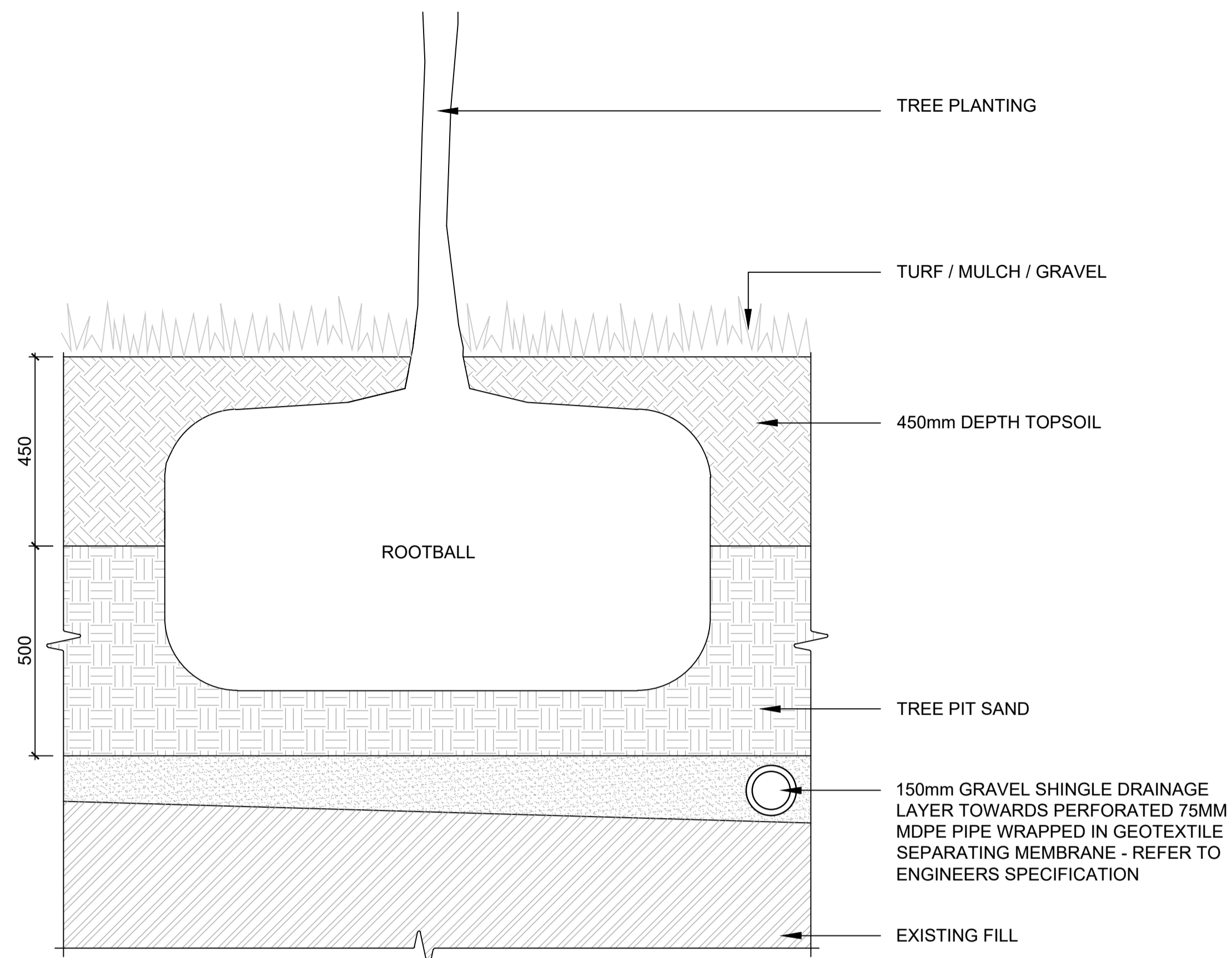

01 TYPICAL TREE SOIL PROFILE
SCALE: 1:10 @A1

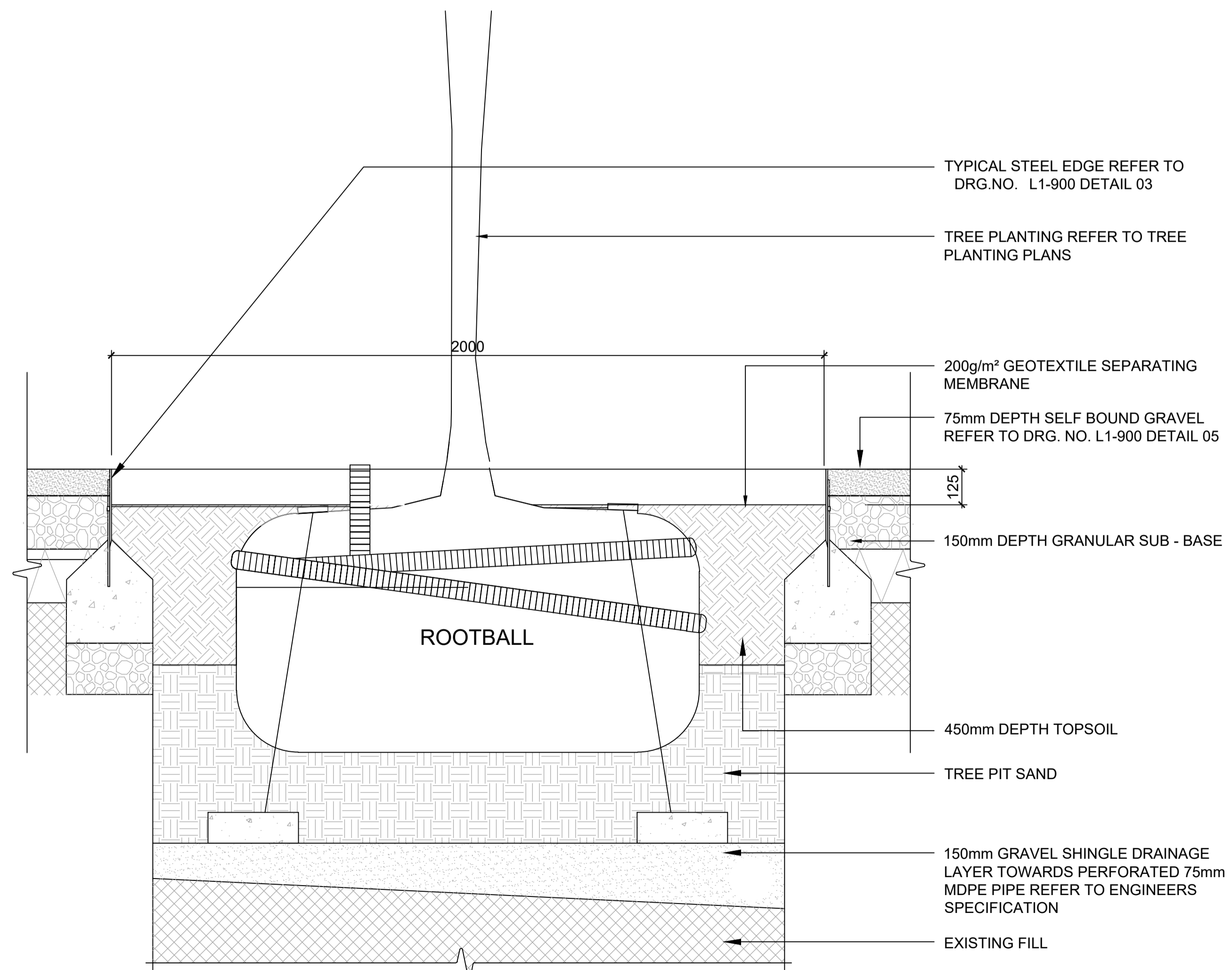

02 TYPICAL TREE DETAIL IN PAVING
SCALE: 1:10 @A1

REFERENCE: THIS DRAWING IS NOT FOR CONSTRUCTION

**SR
LA**

SIMON RONAN LANDSCAPE ARCHITECTS

Cork Office
Levis Quay
Sillibereen
Co. Cork
Ireland
A94A431

Dublin Office
25 Glengarriff Parade
Phibsborough
Dublin 7
Ireland
D07 XF25

simon@simonronan.com +353 86 056 3434

TREE DETAILS
L - 903

SCALE AS SHOWN
A1

PURPOSE OF DRAWING - PLANNING

ROSS ROAD KILLARNEY

THIS DRAWING IS TO BE READ IN CONJUNCTION WITH ALL RELEVANT CONSULTANT'S DRAWINGS
AND SPECIFICATIONS TO BE SUPPLIED TO THE CLIENT.
NO DIMENSIONS TO BE CALLED FROM THIS DRAWING.
NO PART OF THIS DOCUMENT MAY BE REPRODUCED OR
TRANSMITTED IN ANY FORM OR BY ANY MEANS,
ELECTRONIC OR MECHANICAL, WITHOUT THE WRITTEN
CONSENT OF SIMON RONAN LANDSCAPE ARCHITECTS.
THIS DOCUMENT IS THE PROPERTY OF SIMON RONAN LANDSCAPE ARCHITECTS.
IT IS TO BE USED ONLY FOR THE PROJECT AND SITE SPECIFICALLY IDENTIFIED.
IT IS NOT TO BE USED FOR ANY OTHER PROJECT OR SITE.
SIMON RONAN LANDSCAPE ARCHITECTS

JULY 2025

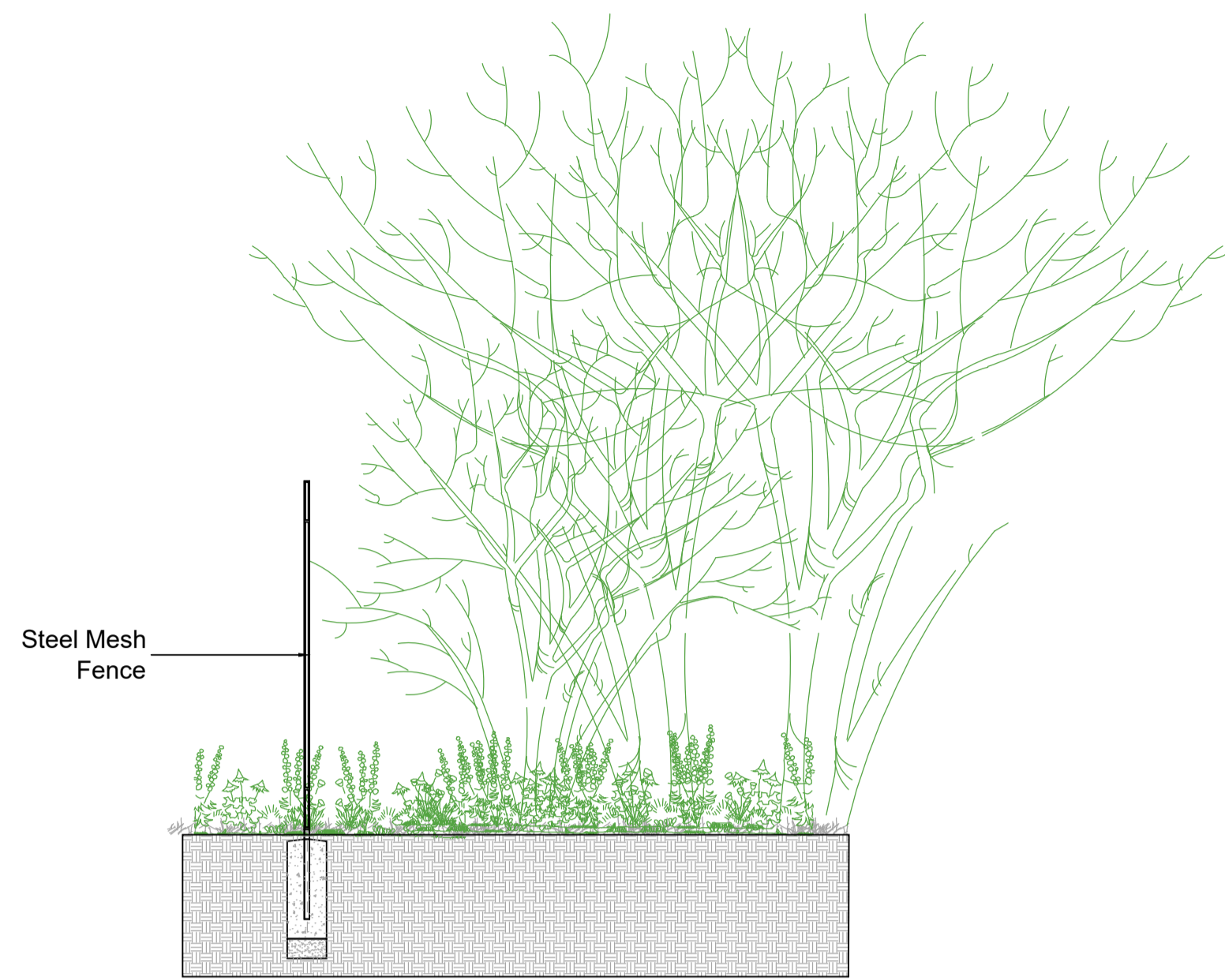

BT1 EXISTING HEDGROW RETAINED AND ENHANCED & PROPOSED STEEL FENCE
SCALE: 1:30 @A1

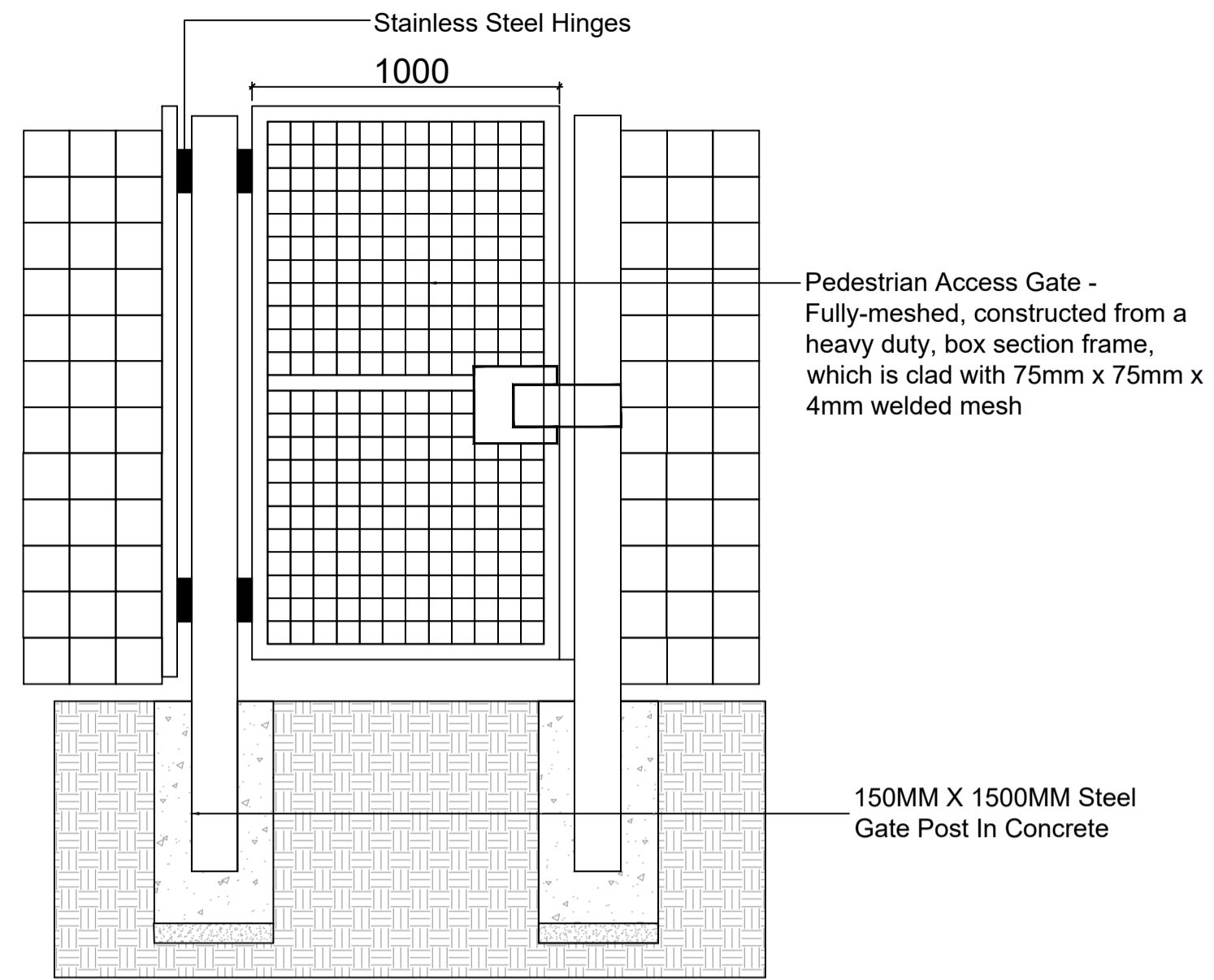

BT3 PEDESTRIAN FENCE
SCALE: 1:20 @A1

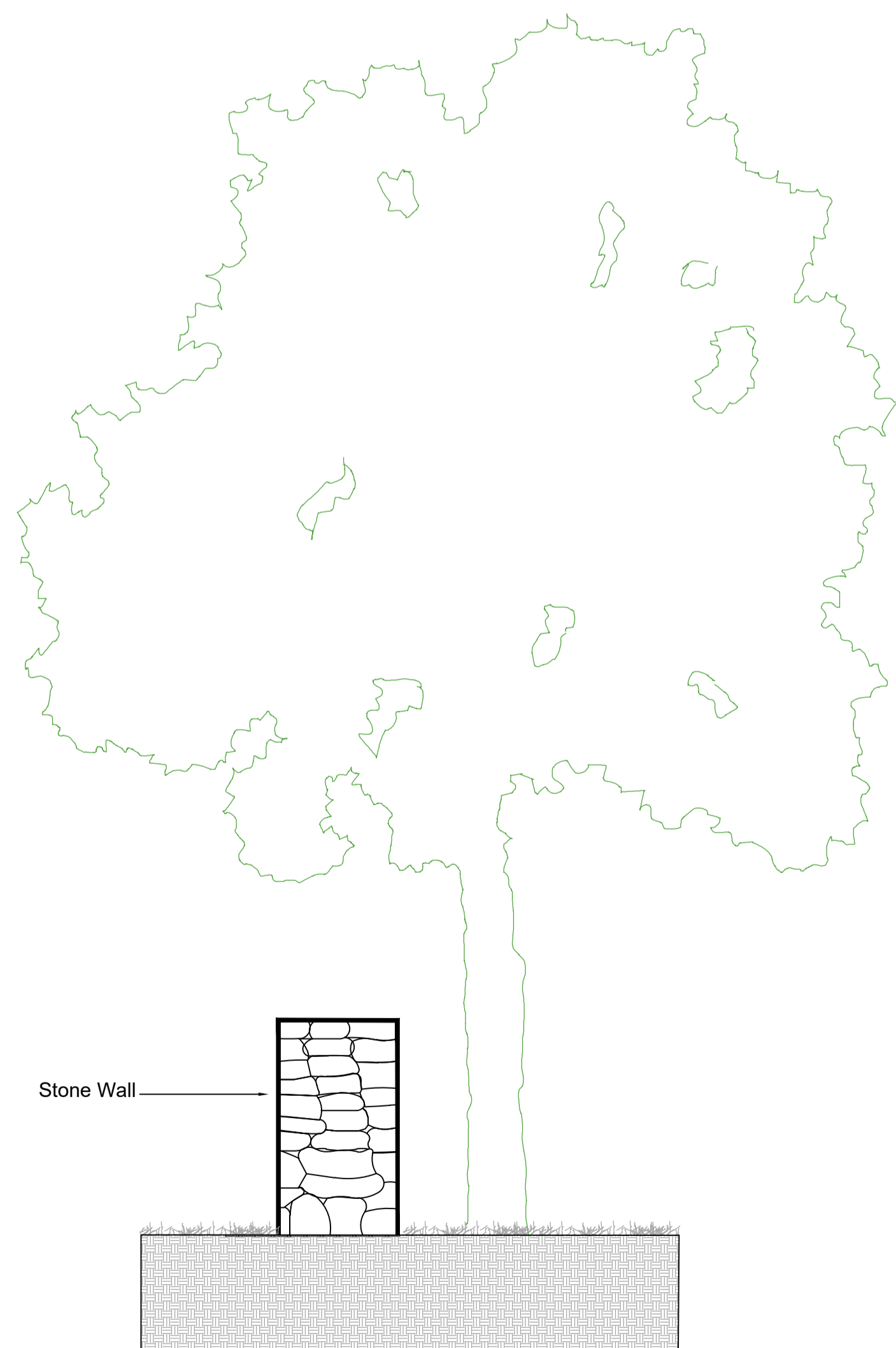

BT2 PROPOSED STONE WALL TO MATCH EXISTING
SCALE: 1:30 @A1

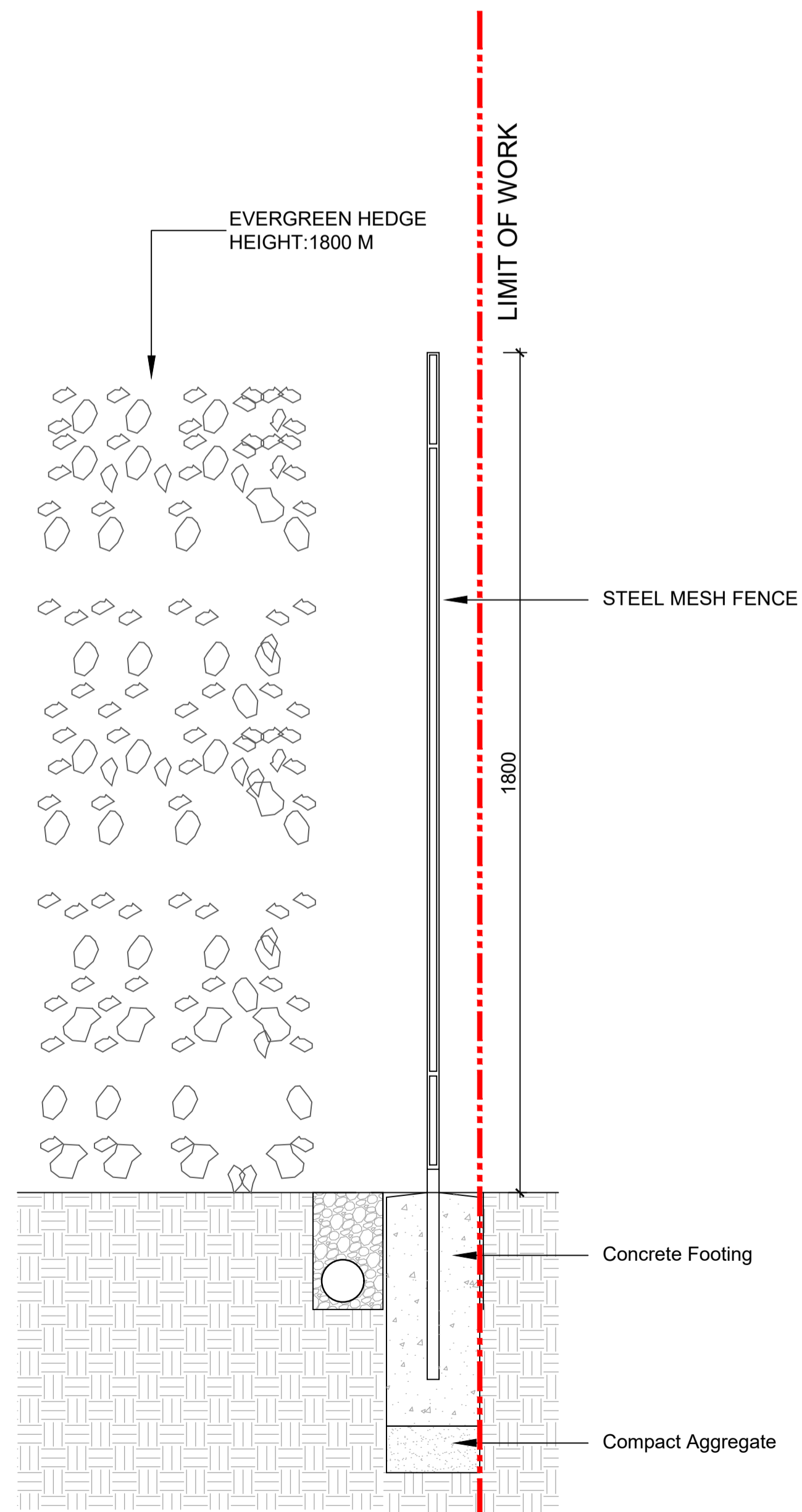

BT4 PROPOSED NATIVE HEDGROW AND STEEL MESH FENCE
SCALE: 1:10 @A1

REFERENCE: THIS DRAWING IS NOT FOR CONSTRUCTION

**SR
LA**

SIMON RONAN LANDSCAPE ARCHITECTS

Cork Office
Levis Quay
Shillbreen
Co. Cork
Ireland
A94A431
simon@simonronan.com

Dublin Office
25 Glengarriff Parade
Phibsborough
Dublin 7
Ireland
D07 XF25
+353 86 056 3434

BOUNDARY DETAILS
L - 904

SCALE AS SHOWN
A1

PURPOSE OF DRAWING - PLANNING

ROSS ROAD KILLARNEY

THIS DRAWING IS TO BE READ IN CONJUNCTION WITH ALL NECESSARY CONSULTANT'S DRAWINGS
AND SPECIFICATIONS TO BE REFERENCED TO IN THE RELEVANT CONTRACT DOCUMENTS.
NO DIMENSIONS TO BE CALLED FROM THIS DRAWING.
NO PART OF THIS DOCUMENT MAY BE REPRODUCED OR
TRANSMITTED IN ANY FORM OR BY ANY MEANS, ELECTRONIC OR MECHANICAL, WITHOUT THE
WRITTEN PERMISSION OF THE ARCHITECT. THIS DRAWING IS THE PROPERTY OF THE ARCHITECT
AND IS NOT TO BE LOANED, REPRODUCED, COPIED, OR IN ANY MANNER DISSEMINATED WITHOUT THE
WRITTEN PERMISSION OF THE ARCHITECT.

JULY 2025

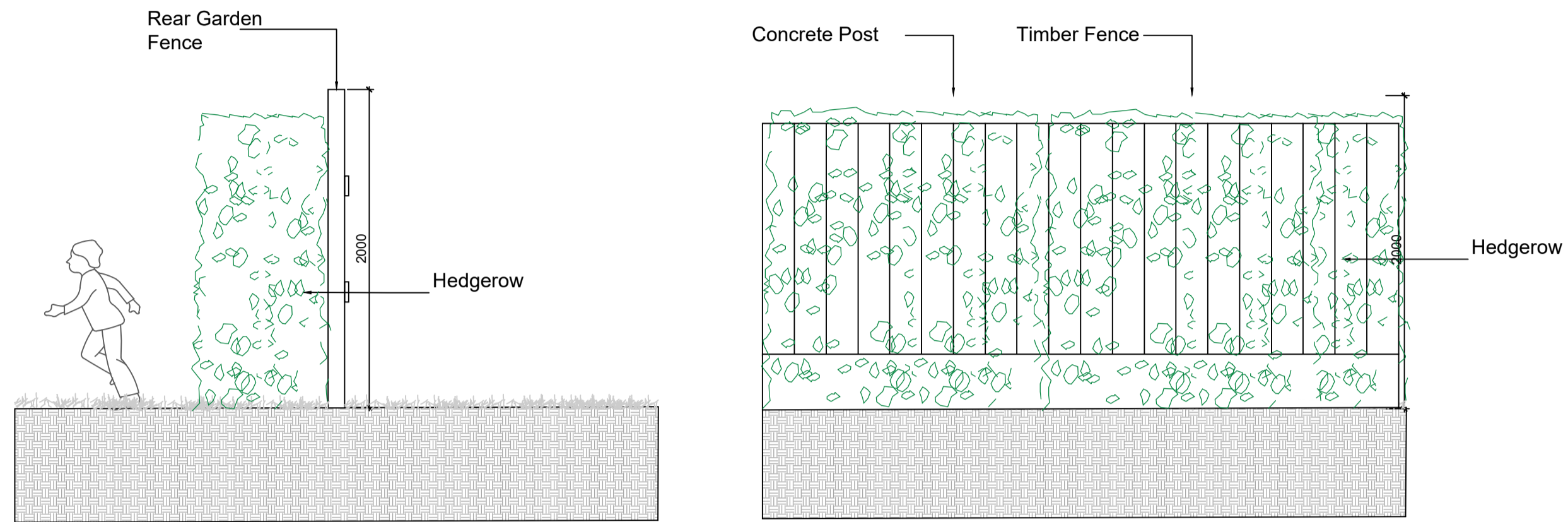

BT5 CONCRETE POST AND TIMBER FENCE INFILL WITH PROPOSED NATIVE HEDGE
SCALE: 1:30 @A1

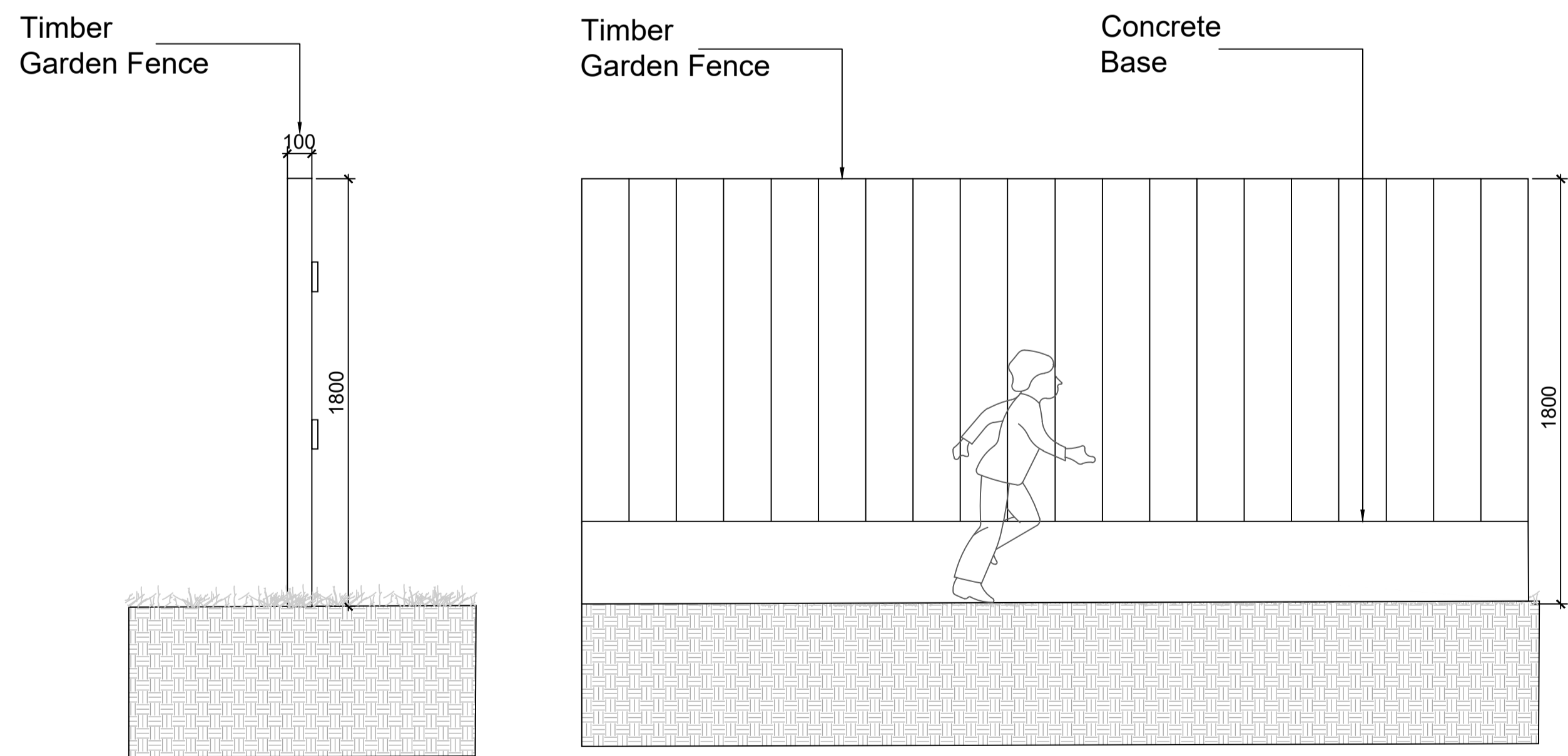

BT6 CONCRETE POST AND TIMBER FENCE INFILL
SCALE: 1:20 @A1

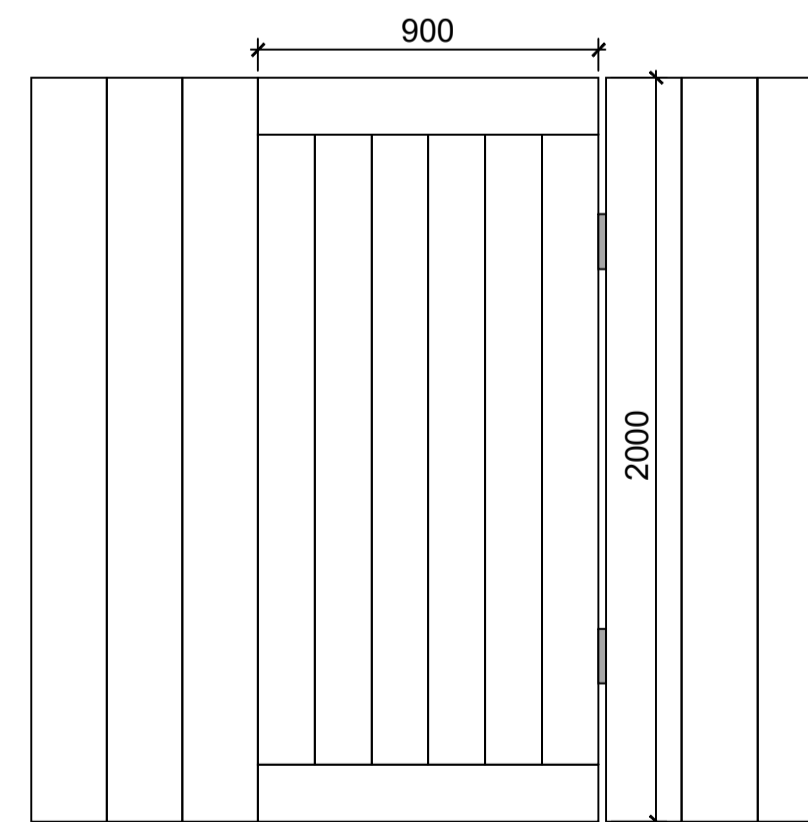

BT7 TIMBER GATE
SCALE: 1:20 @A1

REFERENCE: THIS DRAWING IS NOT FOR CONSTRUCTION

**SR
LA**

SIMON RONAN LANDSCAPE ARCHITECTS

Cork Office
Levis Quay
Shillbreen
Co. Cork
Ireland
A94A431

Dublin Office
25 Glengarriff Parade
Phibsborough
Dublin 7
Ireland
D07 XF25

simon@simonronan.com

+353 86 056 3434

BOUNDARY DETAILS
L - 905

SCALE AS SHOWN
A1

PURPOSE OF DRAWING - PLANNING

ROSS ROAD KILLARNEY

THIS DRAWING IS TO BE READ IN CONJUNCTION WITH ALL PREVIOUS CONSULTANT'S DRAWINGS.
NO DIMENSIONS TO BE SCALED FROM THIS DRAWING.
NO PART OF THIS DOCUMENT MAY BE REPRODUCED OR
TRANSMITTED IN ANY FORM OR BY ANY MEANS,
ELECTRONIC OR MECHANICAL, WITHOUT THE WRITTEN PERMISSION
OF THE UNDERSIGNED ARCHITECTS. ANY UNAUTHORIZED REPRODUCTION
OR ALTERATION OF THIS DOCUMENT IS PROHIBITED AND WILL BE
PROSECUTED TO THE FULL EXTENT OF THE LAW.

JULY 2025

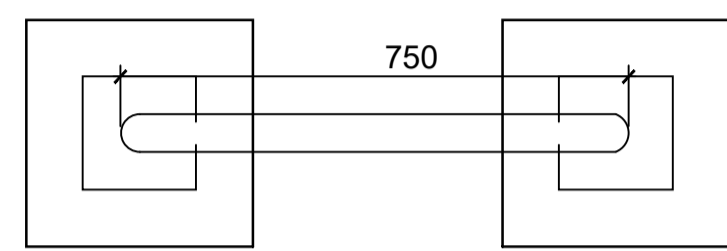
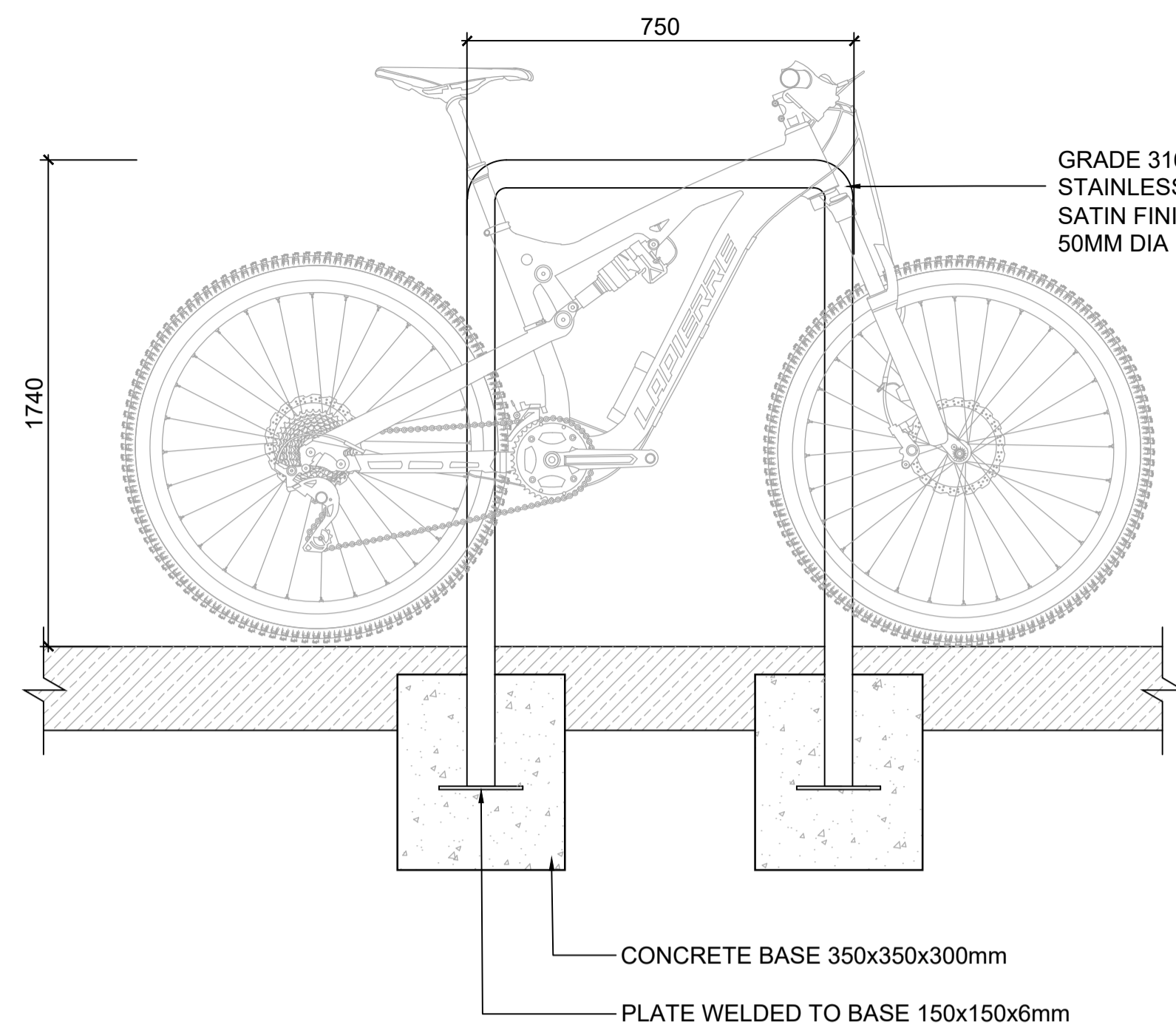
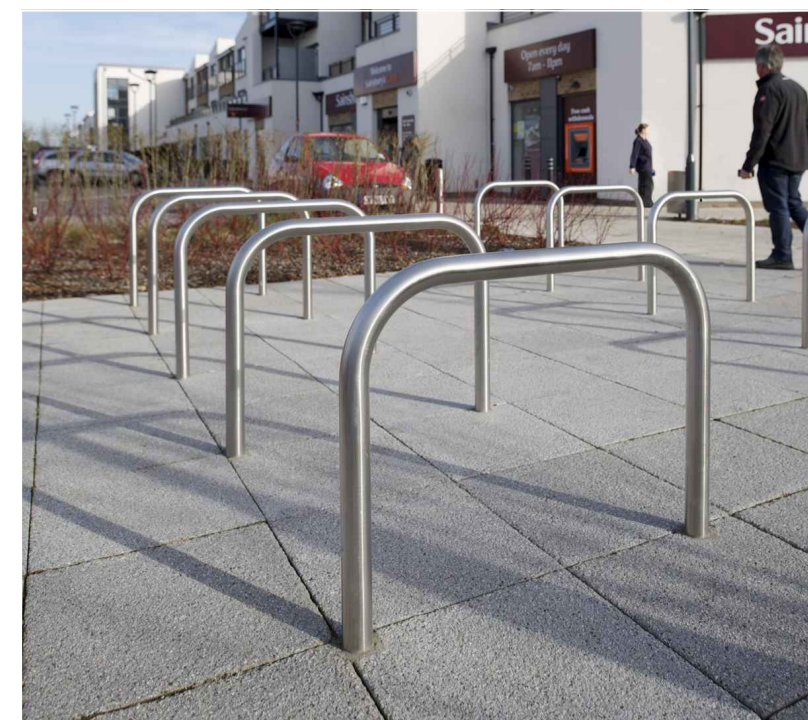

02 TYPICAL SHEFFIELD STAND DETAIL
SCALE: 1:20 @A1

01 L1: s11.3 OMOS LITTER BIN - PUBLIC REALM

S11.3 LITTER BIN
DESCRIPTION
316 GRADE STAINLESS STEEL WITH SATIN FINISH OUTER CONSTRUCTION ON LEVEL ADJUSTMENT GALVANIZED BASE. OMOS PATENTED ASHTRAY. FRONT OPENING WITH CONCEALED STAINLESS STEEL HINGE AND SLAM LATCH. 90L LINER.

DIMENSIONS
HEIGHT 1070MM, WIDTH 530MM, DEPTH 400MM.
CAPACITY 90L.
WEIGHT 62KG.

OPTIONS
GALVANIZED OR PLASTIC LINER.
CHOICE OF DECAL.
WIDE OR CHAMFER APERTURE.

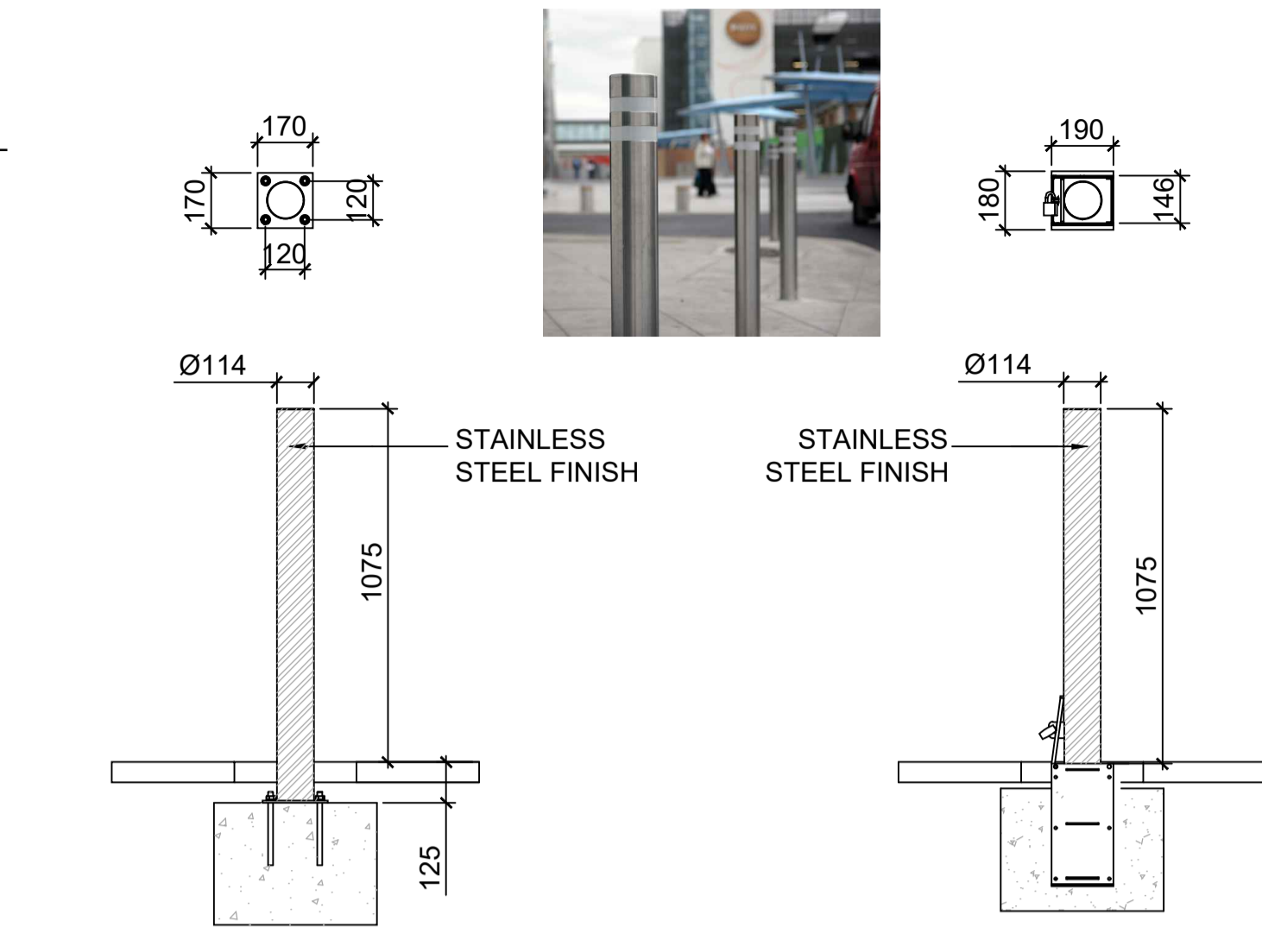
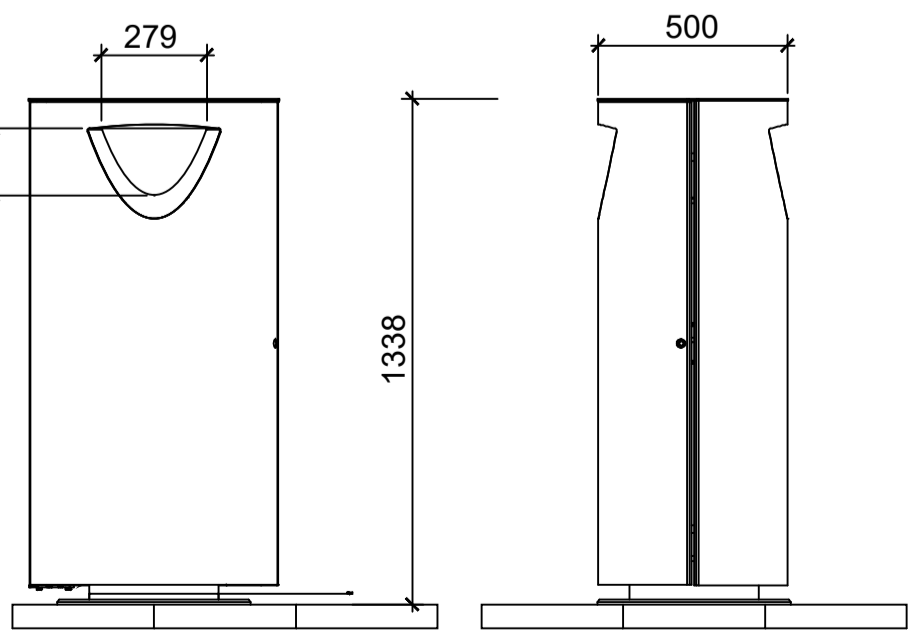
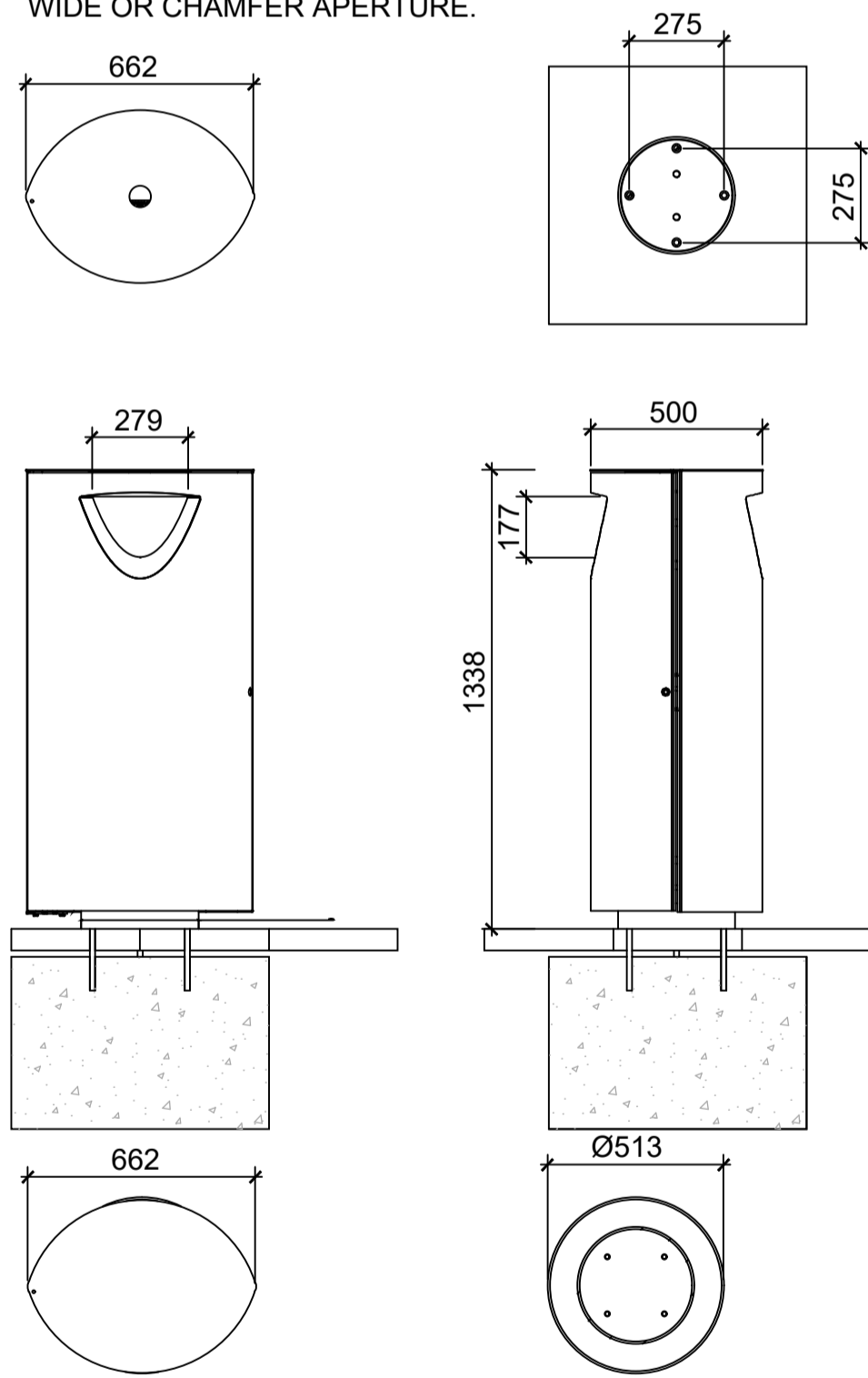

06 BO1: FIXED BOLLARD DETAIL
SCALE: 1:20 OMOS S23 OR SIMILAR APPROVED

07 BO2: REMOVABLE BOLLARD DETAIL
SCALE: 1:20 OMOS S23 OR SIMILAR APPROVED

BACKED EXTENDED BENCH, 3 M LONG EACH
VERSIONS: LWD150B PINE WOOD LWD150T TROPICAL WOOD
STRUCTURE TYPE: MADE OF HARDWOODEN GRATE CONNECTED TO STEEL STRUCTURE BY MEANS OF STAINLESS STEEL SCREW JOINTS.
COATING: STEEL STRUCTURE TREATED WITH PROTECTIVE ZINC AND POWDER COATING.
SUPPORTING FRAME: WELDED OF STEEL SHEET AND TUBES.
SEAT: 15 BOARDS MADE OF HARDWOOD WITH A RECTANGULAR SECTION, 3,000 MM LONG.
BACKREST: 1 BOARD MADE OF HARDWOOD WITH A SQUARE SECTION, 3,000 MM LONG.
COLOUR OPTIONS: NATURAL COLOUR OF USED WOOD. STEEL STRUCTURE ZINC-COATED.
ANCHORING: FREELY LAID ON THE PAVING - ADJUSTABLE LEGS. ALTERNATELY ANCHORING UNDER THE PAVING INTO CONCRETE FOUNDATION BY THREADED RODS. NO MATERIAL CAN BE BETWEEN CONCRETE FOUNDATION AND PAVING.
ALL STREET FURNITURE ELEMENTS MUST BE PROPERLY ANCHORED ACCORDING TO THE PRODUCER'S TECHNICAL INSTRUCTIONS. THE MANUFACTURER DECLINES RESPONSIBILITY FOR ANY DAMAGES CAUSED BY CARELESS USE OR BY NON-COMPLIANCE WITH THE INSTRUCTIONS.
WEIGHT: LWD150B 151 KG LWD150T 225 KG
OPTION: STEEL STRUCTURE TREATED WITH POWDER COATING.



04 B1: TYPICAL TIMBER STRAIGHT BENCH DETAILS MMCITE PARK BENCH WITH BACKREST LWD150t
SCALE: 1:20 @A1

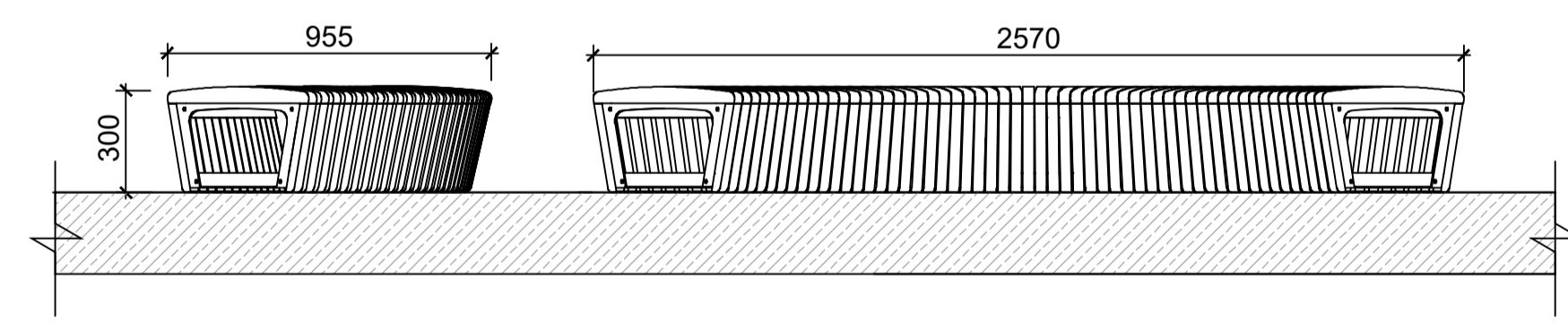
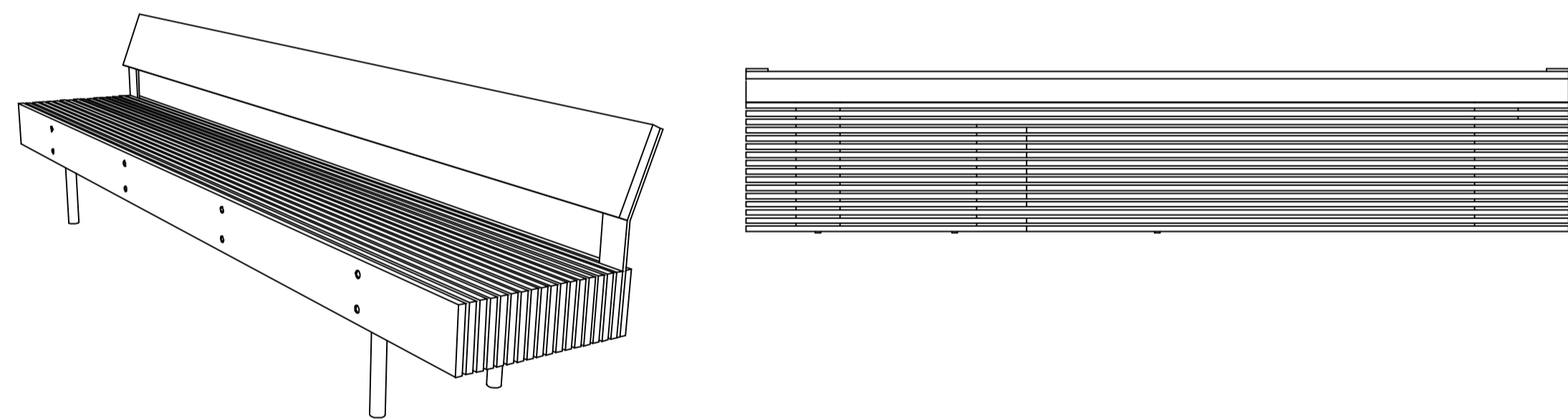
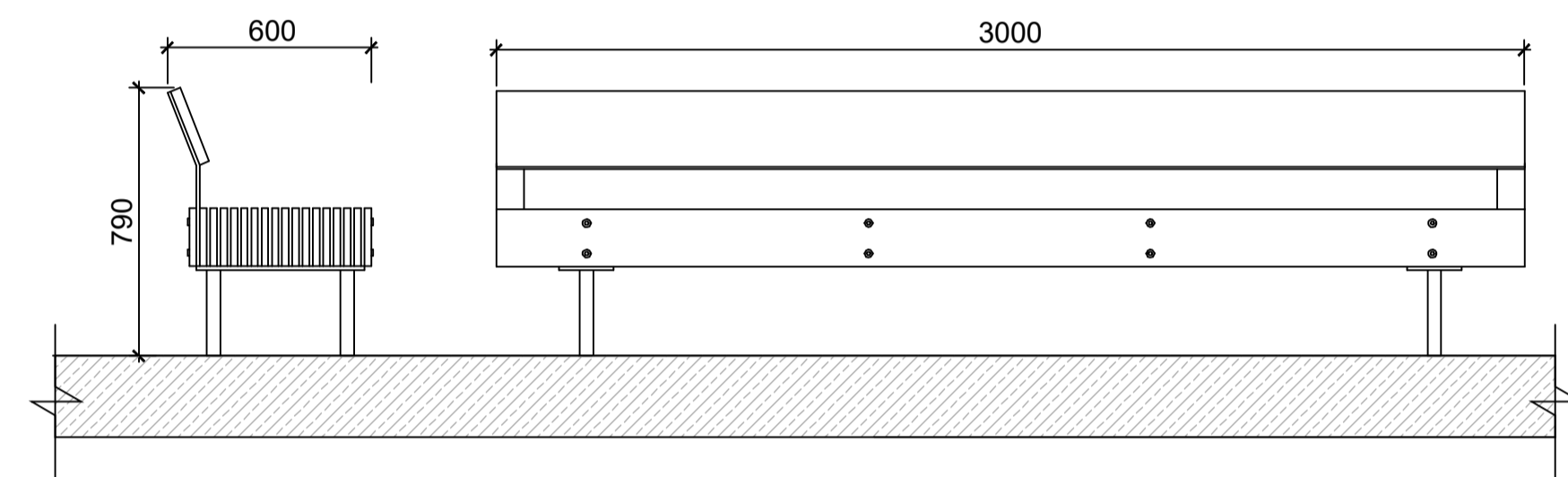

05 B2: TYPICAL TIMBER CURVED BENCH DETAILS MMCITE TWO SIDED CURVED SEAT LPC12-ae-t
SCALE: 1:20 @A1

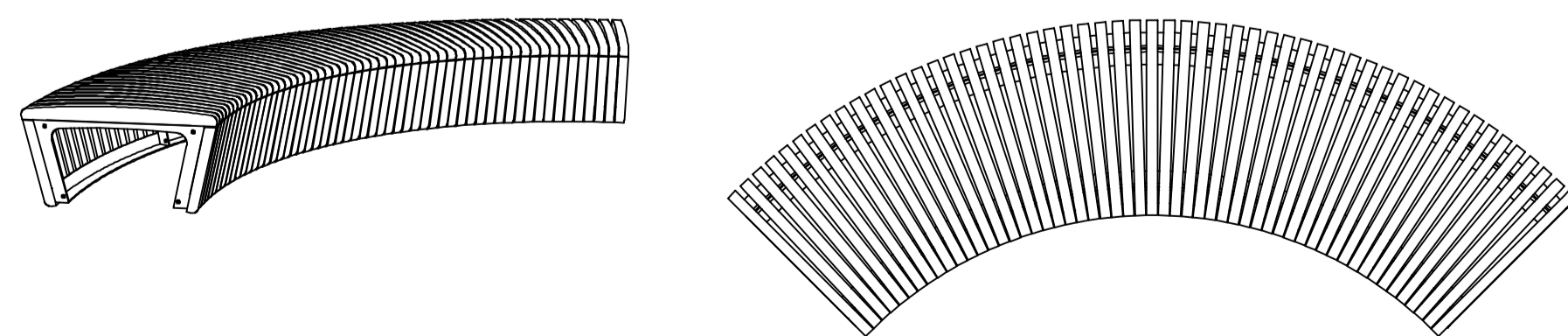

BOTH-SIDED SEAT, 2.2 M LONG
VERSIONS: LPC12-AET TROPICAL WOOD, ARCHED SEAT
STRUCTURE TYPE: WOODEN GRATE CONNECTED TO STEEL STRUCTURE BY MEANS OF STAINLESS STEEL SCREW JOINTS.
THE ARCHED SEAT OF MIDDLE LENGTH OF ABOUT 2.5 M, 90° OF SECTOR.
COATING: STEEL STRUCTURE IS TREATED WITH PROTECTIVE ZINC COATING AND POWDER COATING.
SUPPORTING FRAME: BOTH SIDE FRAMES WELDED OF STEEL SHEET NC LASER CUT-SHAPES.
SEAT: WOODEN LAMELLAS OF RECTANGULAR CROSS SECTION.
WEIGHT: LPC12-AET 96,7 KG



REFERENCE: THIS DRAWING IS NOT FOR CONSTRUCTION

SR LA

SIMON RONAN LANDSCAPE ARCHITECTS

Cork Office
Leavis Quay
Shillbreenan
Co. Cork
Ireland
A94A431
simon@simonronan.com

Dublin Office
25 Glengarriff Parade
Phibsborough
Dublin 7
Ireland
D07 XF25
+353 86 056 3434

FURNITURE DETAILS
L - 906
SCALE AS SHOWN
A1

PURPOSE OF DRAWING - PLANNING

ROSS ROAD KILLARNEY

THIS DRAWING IS TO BE READ IN CONJUNCTION WITH RELEVANT CONSULTANTS DRAWINGS.
ALL DIMENSIONS TO BE CHECKED ON SITE.
NO DIMENSIONS TO BE SCALED FROM THIS DRAWING.
REMARKS OF THIS DOCUMENT MAY BE REPRODUCED OR TRANSMITTED IN ANY FORM OR BY ANY MEANS, ELECTRONIC OR MECHANICAL, WITHOUT PERMISSION IN WRITING FROM THE ARCHITECTS.
OF THE ARCHITECTS' OFFICE FOR THE PROJECT FOR WHICH EXCEPT AS OTHERWISE PROVIDED IN THE DRAWING OR OTHERWISE AGREED IN WRITING.

JULY 2025